Implementing a Bootloader for the PIC16F87X

*Author: Mike Garbutt
Microchip Technology Inc.*

INTRODUCTION

The PIC16F87X family of microcontrollers has the ability to write to their own program memory. This feature allows a small bootloader program to receive and write new firmware into memory. This application note explains how this can be implemented and discusses the features that may be desirable.

In its most simple form, the bootloader starts the user code running, unless it finds that new firmware should be downloaded. If there is new firmware to be downloaded, it gets the data and writes it into program memory. There are many variations and additional features that can be added to improve reliability and simplify the use of the bootloader, some of which are discussed in this application note.

The general operation of a bootloader is discussed in the OPERATION section. Appendix A contains assembly code for a bootloader developed for the PIC16F877 and key aspects of this bootloader are described in the IMPLEMENTATION section.

For the purpose of this application note, the term “boot code” refers to the bootloader code that remains permanently in the microcontroller and the term “user code” refers to the user’s firmware written into FLASH memory by the boot code.

FEATURES

The more common features a bootloader may have are listed below:

- Code at the Reset location.
- Code elsewhere in a small area of memory.
- Checks to see if the user wants new user code to be loaded.
- Starts execution of the user code if no new user code is to be loaded.
- Receives new user code via a communication channel if code is to be loaded.
- Programs the new user code into memory.

OPERATION

The boot code begins by checking to see if there is new user code to be downloaded. If not, it starts running the existing user code. If there is new user code to be downloaded, the boot code receives and writes the data into program memory. There are many ways that this can be done, as well as many ways to ensure reliability and ease of use.

Integrating User Code and Boot Code

The boot code almost always uses the Reset location and some additional program memory. It is a simple piece of code that does not need to use interrupts; therefore, the user code can use the normal interrupt vector at 0x0004. The boot code must avoid using the interrupt vector, so it should have a program branch in the address range 0x0000 to 0x0003.

The boot code must be programmed into memory using conventional programming techniques, and the configuration bits must be programmed at this time. The boot code is unable to access the configuration bits, since they are not mapped into the program memory space. Setting the configuration bits is discussed in the next section.

In order for the boot code to begin executing the user code, it must know where the code starts. Since the boot code starts at the Reset vector, the user code cannot start at this location. There are two methods for placing the starting point of the user code.

One method is to use an `ORG` directive to force the user code to start at a known location, other than the Reset vector. To start executing the user code, the boot code must branch to this fixed location, and the user code must always use this same location as its start address.

An alternative method is to start the user code at the normal Reset vector and require that the user code has a `goto` instruction in the first four instructions to avoid the interrupt vector. These four instructions can then be relocated by the boot code and programmed into the area of program memory used by the boot code. This simplifies the development of code for use with the bootloader, since the user code will run when programmed directly into the chip without the boot code present. The boot code must take care of paging and banking so the normal Reset conditions apply before executing the relocated code.

FIGURE 1: INTEGRATING USER CODE WITH BOOT CODE

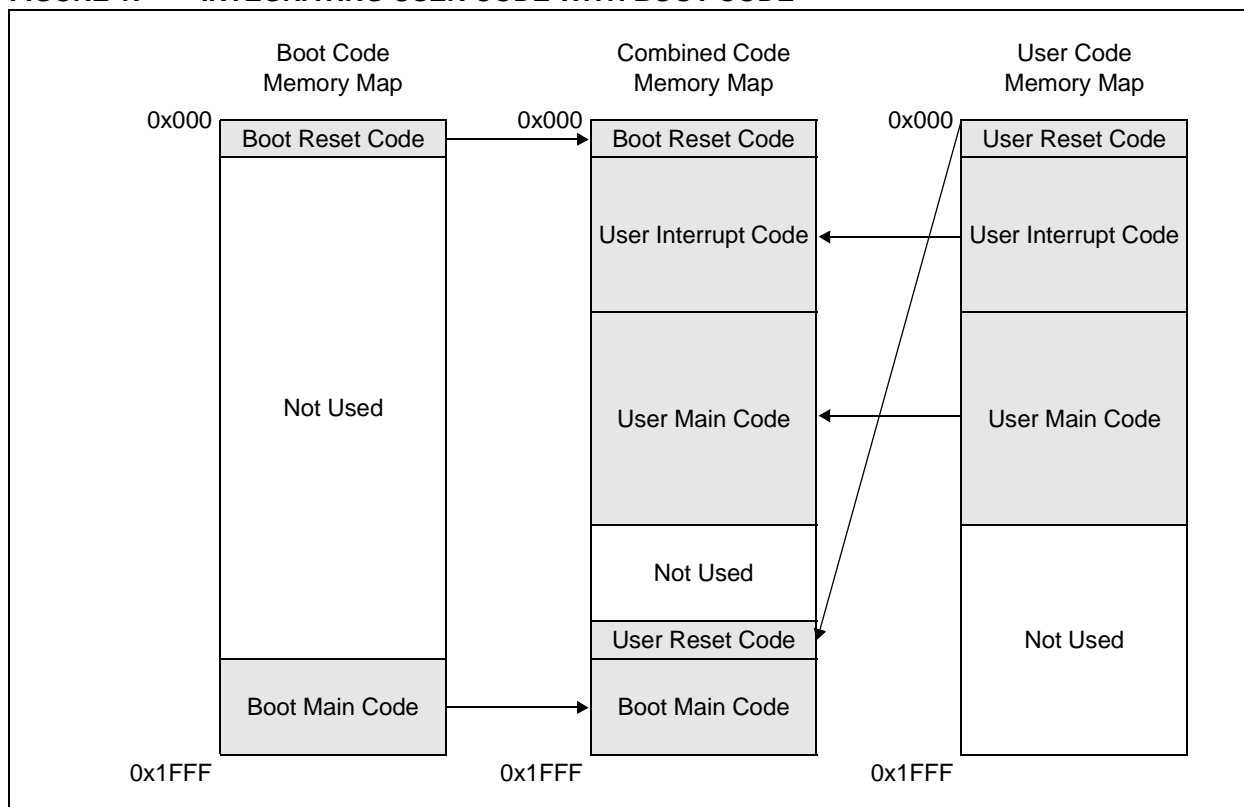

Configuration Bits

The configuration bits cannot be changed by the boot code since they are not mapped into the program memory space. This means that the following configuration options must be set at the time that the boot code is programmed into the device and cannot be changed:

CPx	Program Memory Code Protection Enable
DEBUG	In-Circuit Debugger Mode Enable
WRT	Program Memory Write Enable
CPD	Data EEPROM Code Protection Enable
LVP	Low Voltage In-Circuit Programming Enable
BODEN	Brown-out Reset Enable
PWRTE	Power-up Timer Enable
WDTE	Watchdog Timer Enable
FOSCx	Oscillator Selection

Most of these configuration options are hardware or design-dependent, and being unable to change them when the user code changes is of no consequence.

The various PIC16F87X devices have different code protection implementations. Please consult the appropriate data sheet for details.

Some devices (such as the PIC16F877), can code protect part of the program memory and prevent internal

writes to this protected section of memory. This can be used to protect the boot code from being overwritten, but also prevents the user code from being code protected, however.

On some devices, code protecting all the program memory still allows internal program memory write cycles. This provides security against the user code being read out of the chip, but does not allow the boot code to be protected from being overwritten.

Data EEPROM Code Protection Enable would normally not need to be set, unless data is programmed into the data EEPROM when the boot code is originally programmed and this data needs to be protected from being overwritten by the user code.

Program Memory Write Enable must be enabled for the boot code to work, since it writes to program memory. Low Voltage In-Circuit Serial Programming (ICSP™) enable only needs to be set if the user wishes to program the PICmicro MCU in-circuit, using logic level signals on the RB3, RB6 and RB7 pins. Since the purpose of the boot code is to program user code into the PICmicro MCU, in most cases, it would be redundant to have facilities for low voltage ICSP.

If the Watchdog Timer is enabled, then the boot code must be written to support the Watchdog Timer and all user code will have to support the Watchdog Timer.

Determining Whether to Load New Code or to Execute User Code

After a Reset, the boot code must determine whether to download new user code. If no download is required, the bootcode must start execution of existing user code, if available.

There are many ways to indicate whether or not new user code should be downloaded. For example, by testing a jumper or switch on a port pin, polling the serial port for a particular character sequence, or reading an address on the I²C™ bus. The particular method chosen depends on the way that user code is transferred into the microcontroller. For example, if the new user code is stored on an I²C EEPROM that is placed in a socket on the board, then an address in the EEPROM could be read to determine whether a new EEPROM is present.

If an error occurred while downloading new user code, or the bootloader is being used for the first time, there might not be valid user code programmed into the microcontroller. The boot code should not allow faulty user code to start executing, because unpredictable results could occur.

Receiving New User Code to Load into Program Memory

There are many ways that the microcontroller can receive the new firmware to be written into program memory. A few examples are from a PC over a serial port, from a serial EEPROM over an I²C or SPI™ bus, or from another microcontroller through the parallel slave port.

The boot code must be able to control the reception of data, since it cannot process any data sent to it while it is writing to its own program memory. In the case of data being received via RS-232, there must be some form of flow control to avoid data loss.

The data received by the boot code will usually contain more than just program memory data. It will normally contain the address to which the data is to be written and perhaps a checksum to detect errors. The boot code must decode, verify and store the data, before writing it into program memory. The available RAM (GPR registers) of the device limits the amount of data that can be received before writing it to program memory.

Programming the FLASH Program Memory

The PIC16F87X devices have special function registers that are used to write data to program memory. There is a specific sequence of writes to these registers that must be followed to reduce the chances of an unintended program memory write cycle occurring. Because code cannot be executed from the FLASH program memory while it is being written, program execution halts for the duration of the write cycle. Program memory is written one word at a time.

Error Handling

There are several things that can go wrong during execution of the boot code or user code. The bootloader should handle the following error conditions:

- No valid user code written into the chip.
- Error in incoming data.
- Received user code does not have any code at its Reset vector.
- Received user code overlaps boot code.
- User code causes execution into the boot code area.

If the bootloader is being used for the first time, or if the user code is partially programmed because of a previous error, there might not be valid user code programmed into the microcontroller. The boot code should not allow potentially faulty user code to start executing.

The transfer of data can be interrupted, which will cause the boot code to stop receiving data. There are several ways to handle this depending on how the data is being received. For example, the boot code may be able to time-out and request the data to be sent again. The simplest method is to wait, trying to receive more data with no time-out, until the user intervenes and resets the device. Since the boot code needs to leave the most possible program memory space for the user code and also be reliable, the smallest, simplest implementation is often the best.

Incoming data may be corrupted by noise or some other temporary interruption, and this should be detected, otherwise, incorrect data could be programmed. A checksum or other error detection method can be used.

Incorrect use of flow control can result in data being sent to the PICmicro MCU while it is not ready to receive data. This can cause overrun errors that should be handled by the boot code. Once an overrun has occurred, the data is lost and this is essentially the same as a data transfer interruption, discussed above.

In some cases, data could be sent to the microcontroller before the boot code is running, causing part of the data to be lost. If this type of error is possible, then it should be detected. This error may manifest itself as user code that does not seem to have any code at the Reset location and can be detected by checking the addresses being programmed. An alternative is to generate a checksum on all the code that is written into program memory and transmit this to the user for verification, after programming has been completed.

The code developer should take care that the user code does not use the same program memory space that the boot code uses. The exception is the user code at the Reset location that can be relocated, as explained earlier. If the user code does try to use program memory that contains boot code, the boot code should detect the conflicting address and not overwrite itself. In some devices, part of the program memory can be code protected to prevent internal writes to the part of the memory that contains the main boot code. Note that this does not apply to all PIC16F87X devices.

Faulty user code, or a brown-out condition that corrupts the program counter, can cause execution to jump to an unprogrammed memory location and possibly run into the start of the boot code. If the user code at the Reset location is being relocated, as explained earlier, then execution can enter the boot code area if a program branch does not occur in these four relocated instructions. The boot code should trap the program execution to avoid these errors from causing any unintended operation.

When an error is detected, it is useful to indicate this in some way. This can be as simple as turning on an LED, or sending a byte out the serial port. If the system includes a display and the display drivers are incorporated into the boot code, then more sophisticated error messages can be used.

FIGURE 2: FLOWCHART FOR BOOTLOADER

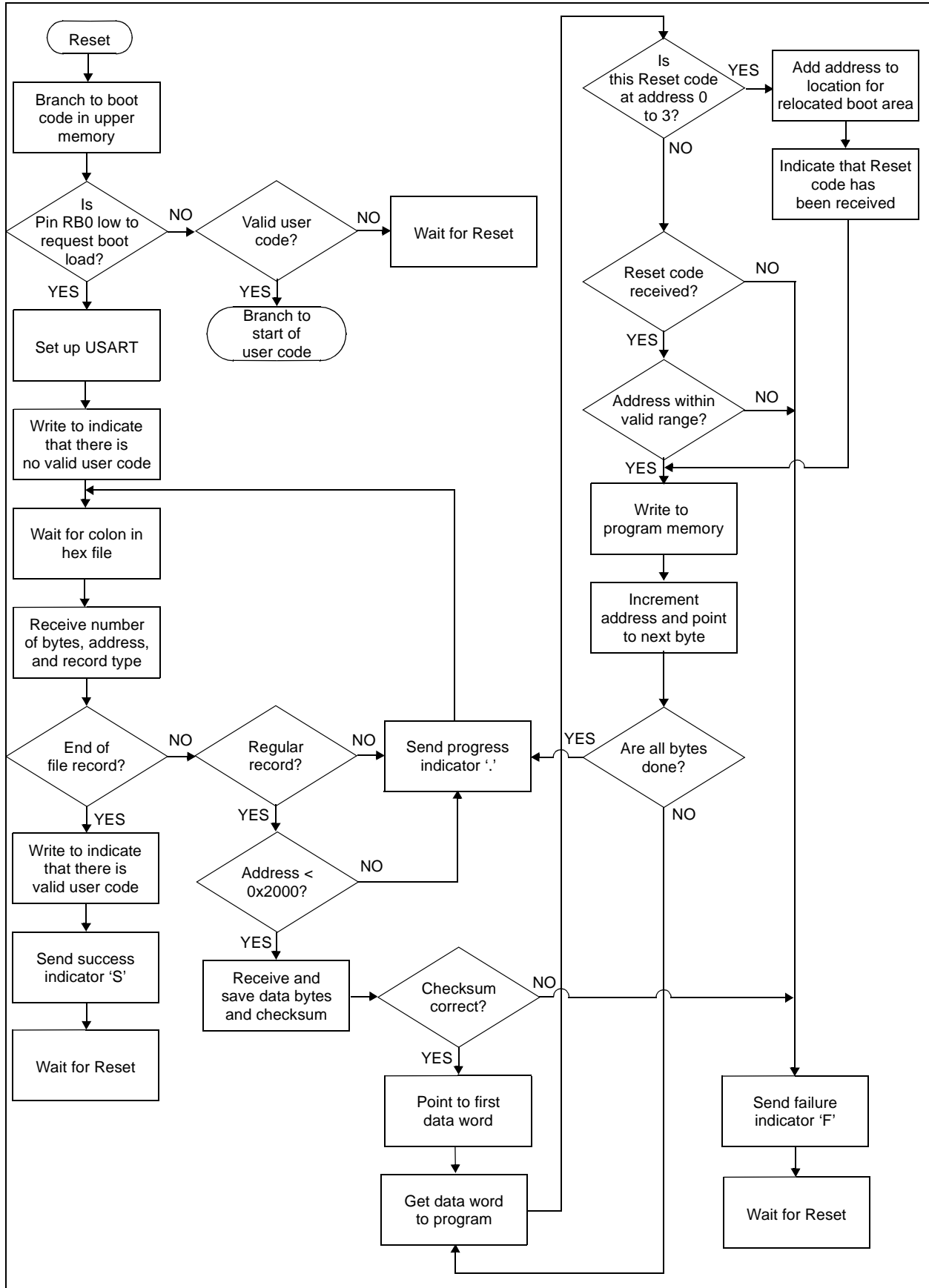
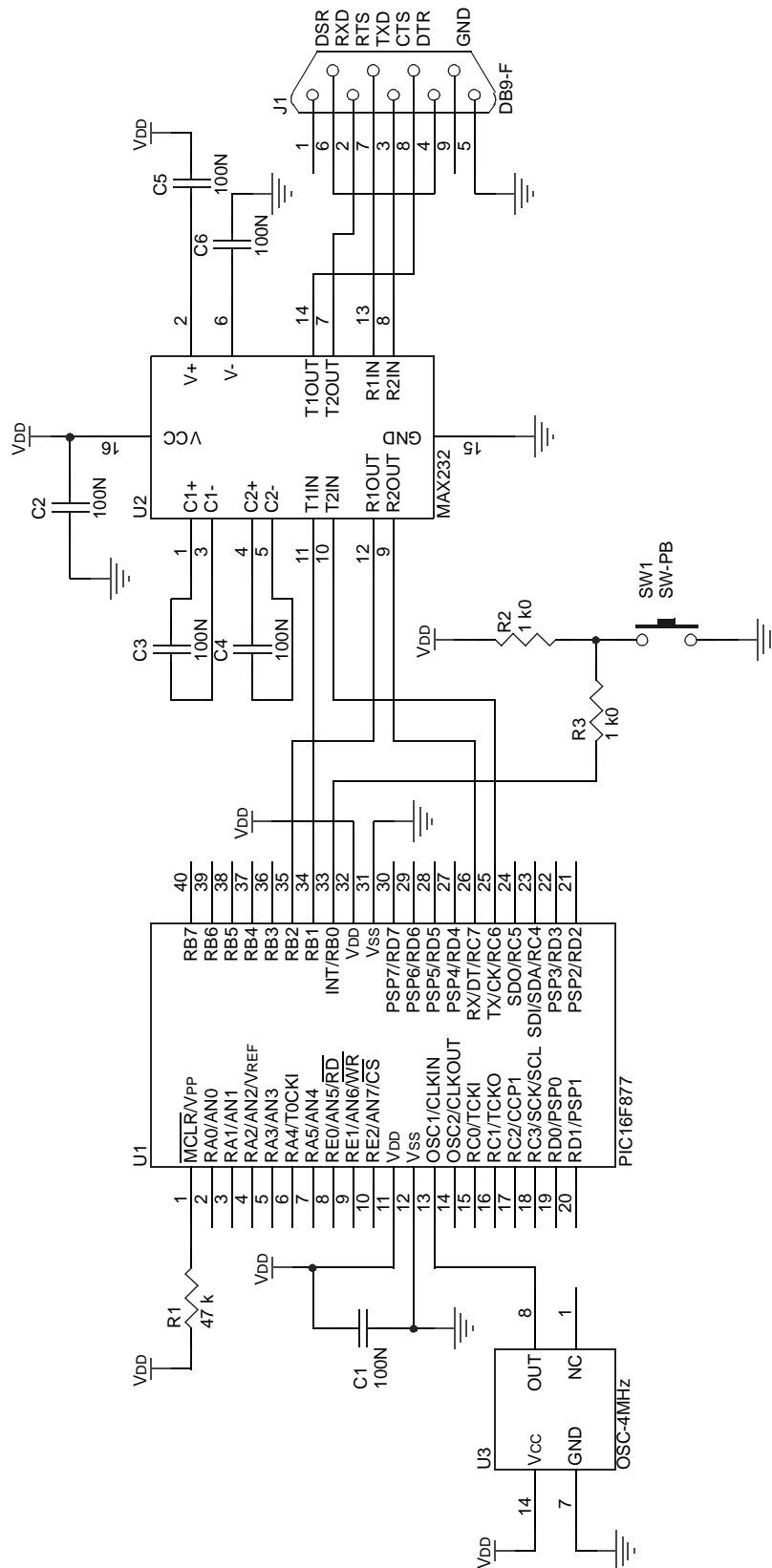

FIGURE 3: SCHEMATIC SHOWING SERIAL PORT AND TEST PIN



IMPLEMENTATION

How this Bootloader Works

The boot code in Appendix A implements a bootloader in a PIC16F877 device. It uses the USART to receive data with hardware handshaking, tests a pin to decide if new user code should be received and includes many of the features discussed in this application note.

Integrating User Code and Boot Code

The code at the Reset location (`ResetVector`) writes to `PCLATH`. To set the page bits, it then jumps to the rest of the boot code in upper memory. The main code is in the upper 224 bytes of memory starting at address `0x1F20` (`StartOfBoot`). The first instructions at this location trap accidental entry into the boot code. The main bootloader routine starts at the address labeled `Main`.

The boot code requires that the user code includes a `goto` instruction in the first four locations after the Reset vector and relocates these four instructions into the boot code section (`StartUserCode`). This simplifies the development of code for use with the bootloader, since the same user code will also run when programmed directly into the chip, without the boot code present. The boot code changes to bank 0 and clears `PCLATH` before executing the relocated code, so that the normal Reset conditions apply. If a program branch does not occur in the four relocated instructions, then program execution is trapped in an endless loop to avoid any unintended operation.

The boot code must be programmed into the PIC16F877 using conventional programming techniques and the configuration bits are programmed at the same time. The configuration bits are defined with a `__CONFIG` directive and cannot be accessed by the boot code, because they are not mapped into the program memory space. The boot code does not use a Watchdog Timer.

Determining Whether to Load new Code or to Execute User Code

The boot code tests port pin `RB0` to determine whether new user code should be downloaded. If a download is required, then the boot code branches to the `Loader` routine that receives the data and writes it into program memory.

If pin `RB0` does not indicate that new user code should be loaded, then a program memory location (labeled `CodeStatus`) is read with routine `FlashRead` to determine whether there is valid user code in the device. If there is valid user code, the boot code transfers execution to the user code by branching to location `StartUserCode`. Otherwise, execution is trapped in an endless loop to avoid this error from causing any unintended operation.

Receiving New User Code to Load into Program Memory

The boot code receives the new firmware as a standard Intel[®] hex file (`INHX8M` format), using the USART in Asynchronous Receiver mode (hex format defined in Appendix B). It is assumed that a PC will be used to send this file via an RS-232 cable, connected to a COM port. Hardware handshaking allows the boot code to stop the PC from transmitting data while FLASH program memory is being written. Since the PICmicro device halts program execution while the FLASH write occurs, it cannot read data from the USART during this time.

Hardware handshaking (described in Appendix C) is implemented using port pin `RB1` as the RTS output and `RB2` as the CTS input. The USART is set to 8-bit Asynchronous mode at 9600 baud in the `SerialSetup` routine. The `SerialReceive` routine enables transmission with the RTS output and waits until a data byte has been received by the USART, before returning with the data. The `SerialTransmit` routine checks the CTS input until a transmission is allowed and then sends a byte out the USART. This is used for transmitting progress indication data back to the PC.

The boot code receives the hex file, one line at a time and stops transmission after receiving each line, while received data is programmed into program memory.

Decoding the Hex File

The boot code remains in a loop, waiting until a colon is received. This is the first character of a line of the hex file. The following four pairs of characters are received and converted into bytes, by calling the `GetHexByte` routine. The number of bytes (divided by two to get the number of words) and the address (divided by two to get a word address) are saved, and the record type is checked for a data record, or end of file record.

If the record type shows that the line contains program memory data, then this data is received, two pairs of characters at a time (using the `GetHexByte` routine), and is stored in an array. The checksum at the end of the line is received and checked, to verify that there were not any errors in the line.

Once the hex file line has been received, hardware handshaking is used to stop further transmission, while the data is written into the program memory. The `<CR>` and `<LF>` characters that are sent at the end of the line are ignored. This gives the handshaking time to take effect by ignoring the byte being transmitted, when the handshaking signal is asserted. Once the data from the line has been programmed, the following lines are received and programmed in the same way, until the line indicating the end of the file has been received. A success indication 'S' is then transmitted out the USART (by the `FileEnd` routine) and the boot code waits for a Reset.

Programming the FLASH Program Memory

Data is written to the FLASH program memory using special function registers. The address is written to the EEADR and EEADRH registers and the first two bytes of data are written to EEDATA and EEDATH. The `FlashWrite` routine is then executed, which writes the data into program memory. The address is then incremented and the next two data bytes are written. This is repeated until all the data from the line of the hex file has been programmed into the FLASH program memory.

Error Handling

There are several things that can go wrong during execution of the boot code or user code, and a number of these error conditions are handled by the boot code. If an error occurs, the boot code traps it by executing an infinite loop, until the user intervenes and resets the device. If an error is detected in the incoming data, then a failure indication 'F' is transmitted. This does not occur in the case of an overflow error, or if the data transmission is halted.

If the bootloader is being used for the first time, or if the user code is partially programmed because of a previous error, there might not be valid user code programmed into the microcontroller. The boot code handles this by writing a status word (`0x3fff`) at a location labeled `CodeStatus`, before programming the FLASH device, and then writing a different status word (`0x0000`) to this same location, when programming of the user code has been completed. The boot code tests this location and only starts execution of the user code, if it sees that the user code was successfully programmed. When the boot code is originally programmed into the PICmicro MCU, the status word indicates that there is not valid user code in the device.

The transfer of data can be interrupted. In this case, the boot code waits, trying to receive more data with no time-out, until the user intervenes and resets the device. Noise, or a temporary interruption, may corrupt incoming data. The Intel hex file includes a checksum on each line and the boot code checks the validity of each line by verifying the checksum.

Incorrect use of flow control can result in data being sent to the PIC16F877, while it is not ready to receive data. This can cause an overrun error in the USART. Once an overrun has occurred, the USART will not move any new data into the receive FIFO and the boot code will be stuck in a loop waiting for more data. This effectively traps the error until the user intervenes by resetting the device.

If the user starts transmitting a hex file before the boot code is running, the boot code may miss the first lines of the file. Since all the lines of a hex file have the same format, it is not normally possible to determine whether the line being received is the first line of the hex file. However, since MPASM generates hex files with addresses in ascending order, the first valid line of the

hex file should contain the code for the Reset vector which is checked by the boot code.

The user code may try to use program memory locations that contain boot code. This is detected by checking the address being programmed and detecting conflicting addresses. The boot code will not overwrite itself and is not code protected.

Faulty user code, or noise that corrupts the program counter, can cause execution to jump to an unprogrammed memory location and possibly run into the start of the boot code. The first instructions in the boot code are an infinite loop that traps execution into the boot code area.

Because the first four instructions in program memory are relocated in the boot code implementation, there must be a program branch within these four instructions. If there is no program branch, then execution is trapped by the boot code.

Using the Bootloader

The procedure for using the bootloader is as follows:

- On the PC, set up the serial port baud rate and flow control (hardware handshaking).
- Connect the serial port of the PIC16F87X device to the serial port of the PC.
- Press the switch to pull pin RB0 low.
- Power up the board to start the boot code running.
- The switch on RB0 can be released if desired.
- From the PC, send the hex file to the serial port.
- A period '.' will be received from the serial port for each line of the hex file that is sent.
- An 'S' or 'F' will be received to indicate success or failure.
- The user must handle a failure by resetting the board and starting over.
- Release the switch to set pin RB0 high.
- Power-down the board and power it up to start the user code running.

On the PC, there are several ways to set up the serial port and to transfer data. This also differs between operating systems.

A terminal program allows the user to set up and send data to a serial port. In most terminal programs, an ASCII or text file can be sent and this option should be used to send the hex file. A terminal program will also show data received on the serial port and this allows the user to see the progress '.' indicators and the success 'S' or failure 'F' indicators. There are many terminal programs available, some of which are available free on the Internet. This boot code was tested using Tera Term Pro, Version 2.3. The user should be aware that some popular terminal programs contain bugs.

A serial port can be set up in a DOS window, using the MODE command and a file can be copied to a serial port, using the COPY command. When using Windows® 95/98, the MODE command does not allow the handshaking signals to be configured. This makes it difficult to use the COM port in DOS. When using Windows NT® or Windows 2000®, the following commands can be used to send a hex file named `filename.hex` to serial port COM1:

```
MODE COM1: BAUD=9600 PARITY=N DATA=8
STOP=1 to=off xon=off odsr=off
octs=on dtr=off rts=on idsr=off

COPY filename.hex COM1:
```

Resources Used

The boot code coexists with the user code on the PIC16F877 and many of the resources used by the boot code can also be used by the user code. The boot code uses the resources listed in Table 1.

TABLE 1: RESOURCES USED BY THE BOOT CODE

Resource	Amount
Program memory	224 words
Data memory	72 bytes
I/O pins	5 pins
Peripherals	USART

The program memory used by the boot code cannot be used for user code, although it is possible to call some of the subroutines implemented in the boot code to save space. The user code can use all the data memory.

The USART can be used by the user code with the two I/O pins for the USART and the I/O pins used for handshaking. The I/O pin used to indicate that the boot code should load new user code, is connected to a switch or jumper. This can be isolated with a resistor and used as an output, so that it is possible to use all the I/O pins used by the bootloader.

In summary, all resources used by the boot code, except program memory, can also be used by the user code.

CONCLUSION

Using a bootloader is an efficient way to allow firmware upgrades in the field. Less than 3% of the total program memory is used by the boot code and the entire program memory available on a PIC16F877 can be programmed in less than one minute at 19,200 baud.

The cost of fixing code bugs can be reduced with a bootloader. Products can be upgraded with new features in the field, adding value and flexibility to the products. The ability to upgrade in the field is an added feature and can enhance the value of a product.

Software License Agreement

The software supplied herewith by Microchip Technology Incorporated (the "Company") for its PICmicro® Microcontroller is intended and supplied to you, the Company's customer, for use solely and exclusively on Microchip PICmicro Microcontroller products.

The software is owned by the Company and/or its supplier, and is protected under applicable copyright laws. All rights are reserved. Any use in violation of the foregoing restrictions may subject the user to criminal sanctions under applicable laws, as well as to civil liability for the breach of the terms and conditions of this license.

THIS SOFTWARE IS PROVIDED IN AN "AS IS" CONDITION. NO WARRANTIES, WHETHER EXPRESS, IMPLIED OR STATUTORY, INCLUDING, BUT NOT LIMITED TO, IMPLIED WARRANTIES OF MERCHANTABILITY AND FITNESS FOR A PARTICULAR PURPOSE APPLY TO THIS SOFTWARE. THE COMPANY SHALL NOT, IN ANY CIRCUMSTANCES, BE LIABLE FOR SPECIAL, INCIDENTAL OR CONSEQUENTIAL DAMAGES, FOR ANY REASON WHATSOEVER.

APPENDIX A: SOURCE CODE – FILE BOOT877.ASM

MPASM 02.40 Released BOOT877.ASM 6-26-2000 14:58:44 PAGE 1

```

LOC OBJECT CODE      LINE SOURCE TEXT
VALUE
00001 ;=====
00002 ; Software License Agreement
00003 ;
00004 ; The software supplied herewith by Microchip Technology Incorporated
00005 ; (the "Company") for its PICmicro® Microcontroller is intended and
00006 ; supplied to you, the Company's customer, for use solely and
00007 ; exclusively on Microchip PICmicro Microcontroller products. The
00008 ; software is owned by the Company and/or its supplier, and is
00009 ; protected under applicable copyright laws. All rights are reserved.
00010 ; Any use in violation of the foregoing restrictions may subject the
00011 ; user to criminal sanctions under applicable laws, as well as to
00012 ; civil liability for the breach of the terms and conditions of this
00013 ; license.
00014 ;
00015 ; THIS SOFTWARE IS PROVIDED IN AN "AS IS" CONDITION. NO WARRANTIES,
00016 ; WHETHER EXPRESS, IMPLIED OR STATUTORY, INCLUDING, BUT NOT LIMITED
00017 ; TO, IMPLIED WARRANTIES OF MERCHANTABILITY AND FITNESS FOR A
00018 ; PARTICULAR PURPOSE APPLY TO THIS SOFTWARE. THE COMPANY SHALL NOT,
00019 ; IN ANY CIRCUMSTANCES, BE LIABLE FOR SPECIAL, INCIDENTAL OR
00020 ; CONSEQUENTIAL DAMAGES, FOR ANY REASON WHATSOEVER.
00021 ;
00022 ;=====

```

```

00023 ;      Filename:      boot877.asm
00024 ;=====
00025 ;      Author:      Mike Garbutt
00026 ;      Company:     Microchip Technology Inc.
00027 ;      Revision:   1.00
00028 ;      Date:       26 June 2000
00029 ;      Assembled using MPASM V2.40
00030 ;=====
00031 ;      Include Files:  pl16f877.inc      V1.00
00032 ;=====
00033 ;      Boot code to receive a hex file containing user code from a
00034 ;      serial port and write it to program memory. Tests a pin to see
00035 ;      if code should be downloaded. Receives hex file using USART and
00036 ;      hardware handshaking. Does error checking on data and writes to
00037 ;      program memory. Waits for reset and then starts user code running.
00038 ;=====
00039
00040      list p=16f877, st=OFF, x=OFF, n=0
00041      errorlevel -302
00042      #include <pl16f877.inc>
00043      LIST
00044      00002 ; P16F877.INC Standard Header File, Version 1.00      Microchip Technology, Inc.
00045
00046      CPD_OFF & _LVP_OFF
00047 ;-----
00048 ;Constants
00049 TEST_INPUT      EQU      0      ;Port B Pin 0 input indicates download
00050 RTS_OUTPUT      EQU      1      ;Port B Pin 1 output for flow control
00051 CTS_INPUT       EQU      2      ;Port B Pin 2 input for flow control
00052
00053 BAUD_CONSTANT   EQU      0x19   ;Constant for baud generator for 9600 baud
00054 ;BAUD_CONSTANT EQU      0x0c   ;Constant for baud generator for 19200 baud
00055 ;Fosc is 4MHz
00056
00057 ;-----
00058 ;Variables in bank0
00059
00060      CBLOCK 0x20
00061      AddressH: 1      ;flash program memory address high byte
00062      AddressL: 1      ;flash program memory address low byte
00063      NumWords: 1      ;number of words in line of hex file
00064      Checksum: 1      ;byte to hold checksum of incoming data
00065      Counter: 1       ;to count words being saved or programmed

```

```

00000025
00000026
00000027
00000028
000066
000067
000068
000069
000070
000071
000072
000073
000074
000075
000076
000077
000078
000079
000080
000081
000082
000083
000084
000085
000086
000087
000088
000089
000090
000091
000092
000093
000094
000095
000096
000097
000098
000099
000100
000101
000102
000103
000104
000105
000106
000107
000108
000109
000110
000111

TestByte:      1      ;byte to show reset vector code received
HexByte:       1      ;byte from 2 incoming ascii characters
DataPointer:   1      ;pointer to data in buffer
DataArray:     0x40   ;buffer for storing incoming data
ENDC

;-----
00072 ;
00073 ;Macros to select the register bank
00074 ;Many bank changes can be optimised when only one STATUS bit changes
00075
00076 Bank0
00077     MACRO
00078     bcf STATUS,RP0
00079     bcf STATUS,RP1
00080     ENDM
00081 Bank1
00082     MACRO
00083     bsf STATUS,RP0
00084     bcf STATUS,RP1
00085     ENDM
00086 Bank2
00087     MACRO
00088     bcf STATUS,RP0
00089     bsf STATUS,RP1
00090     ENDM
00091 Bank3
00092     MACRO
00093     bsf STATUS,RP0
00094     bcf STATUS,RP1
00095     ENDM
00096 ;=====
00097 ;Reset vector code
00098
00099     ORG 0x0000
00100
00101 ResetVector:  movlw high Main
00102                movwf PCLATH      ;set page bits for page3
Message[306]:    Message[306]: Crossing page boundary -- ensure page bits are set.
0002 2F2C        goto Main          ;go to boot loader
00104
00105 ;=====
00106 ;Start of boot code in upper memory traps accidental entry into boot code area
00107
00108     ORG 0x1f20      ;Use last part of page3 for PIC16F876/7
00109     ORG 0x0f20      ;Use last part of page1 for PIC16F873/4
00110     ORG 0x0720      ;Use last part of page0 for PIC16F870/1
00111

```

```

1F20 301F 00112 StartOfBoot:  movlw  high TrapError  ;trap if execution runs into boot code
1F21 008A 00113          movwf  PCLATH    ;set correct page
1F22 2F22 00114 TrapError:   goto    TrapError  ;trap error and wait for reset
00115
00116 ;-----
00117 ;Relocated user reset code to jump to start of user code
00118 ;Must be in bank0 before jumping to this routine
00119
00120 StartUserCode:  clrf   PCLATH    ;set correct page for reset condition
00121          nop                    ;relocated user code replaces this nop
00122          nop                    ;relocated user code replaces this nop
00123          nop                    ;relocated user code replaces this nop
00124          nop                    ;relocated user code replaces this nop
00125 301F 00125          movlw  high TrapError1 ;trap if no goto in user reset code
00126 008A 00126          movwf  PCLATH    ;set correct page
00127 2F2A 00127 TrapError1: goto    TrapError1  ;trap error and wait for reset
00128
00129 ;-----
00130 ;Program memory location to show whether valid code has been programmed
00131
00132 CodeStatus:   DA    0x3fff    ;0 for valid code, 0x3fff for no code
00133
00134 ;-----
00135 ;Main boot code routine
00136 ;Tests to see if a load should occur and if valid user code exists
00137
00138 Main:         Bank0          ;change to bank0 in case of soft reset
00139          btfs   PORTB,TEST_INPUT ;check pin for boot load
00140          goto   Loader        ;if low then do bootload
00141          call   LoadStatusAddr ;load address of CodeStatus word
00142          call   FlashRead     ;read data at CodeStatus location
00143          Bank2          ;change from bank3 to bank2
00144          movf   EEDATA,F      ;set Z flag if data is zero
00145          Bank0          ;change from bank2 to bank0
00146          btfs   STATUS,Z      ;test Z flag
00147 TrapError2:   goto   TrapError2 ;if not zero then is no valid code
00148          goto   StartUserCode ;if zero then run user code
00149
00150 ;-----
00151 ;Start of routine to load and program new code
00152
00153 Loader:       clrf   TestByte  ;indicate no reset vector code yet
00154
00155          call   LoadStatusAddr ;load address of CodeStatus word
00156          movlw  0x3f          ;load data to indicate no program
00157          movwf  EEDATH        ;load data to indicate no program
00158          movlw  0xff          ;load data to indicate no program

```

```

00159          EEDATA
00160      call    FlashWrite      ;write new CodeStatus word
00161
00162      call    SerialSetup     ;set up serial port
00163
00164      ;-----
00165      ;Get new line of hex file starting with ':'
00166      ;Get first 8 bytes after ':' and extract address and number of bytes
00167
00168      GetNewLine:
00169          call    SerialReceive ;get new byte from serial port
00170          xorlw   ':'           ;check if ':' received
00171          btfsz  STATUS,Z
00172          goto   GetNewLine    ;if not then wait for next byte
00173
00174          clrfs  Checksum      ;start with checksum zero
00175
00176          call    GetHexByte    ;get number of program data bytes in line
00177          andlw  0x1F          ;limit number in case of error in file
00178          movwf NumWords
00179          bcf   STATUS,C
00180          rrf   NumWords,F     ;divide by 2 to get number of words
00181
00182          call    GetHexByte    ;get upper half of program start address
00183          movwf AddressH
00184
00185          call    GetHexByte    ;get lower half of program start address
00186          movwf AddressL
00187
00188          bcf   STATUS,C
00189          rrf   AddressH,F     ;divide address by 2 to get word address
00190          rrf   AddressL,F
00191
00192          call    GetHexByte    ;get record type
00193          xorlw  0x01
00194          btfsz STATUS,Z
00195          goto   FileDone
00196
00197          movf  HexByte,W
00198          xorlw 0x00
00199          btfsz STATUS,Z
00200          goto   LineDone
00201
00202          movlw 0xe0
00203          addwf AddressH,W
00204          btfsz STATUS,C
00205          goto   LineDone
00206
00207          goto LineDone
00208
00209          goto LineDone
00210
00211          movlw 0xe0
00212          addwf AddressH,W
00213          btfsz STATUS,C
00214          goto   LineDone
00215
00216          goto LineDone
00217
00218          goto LineDone
00219
00220          goto LineDone
00221
00222          goto LineDone
00223
00224          goto LineDone
00225
00226          goto LineDone
00227
00228          goto LineDone
00229
00230          goto LineDone
00231
00232          goto LineDone
00233
00234          goto LineDone
00235
00236          goto LineDone
00237
00238          goto LineDone
00239
00240          goto LineDone
00241
00242          goto LineDone
00243
00244          goto LineDone
00245
00246          goto LineDone
00247
00248          goto LineDone
00249
00250          goto LineDone
00251
00252          goto LineDone
00253
00254          goto LineDone
00255
00256          goto LineDone
00257
00258          goto LineDone
00259
00260          goto LineDone
00261
00262          goto LineDone
00263
00264          goto LineDone
00265
00266          goto LineDone
00267
00268          goto LineDone
00269
00270          goto LineDone
00271
00272          goto LineDone
00273
00274          goto LineDone
00275
00276          goto LineDone
00277
00278          goto LineDone
00279
00280          goto LineDone
00281
00282          goto LineDone
00283
00284          goto LineDone
00285
00286          goto LineDone
00287
00288          goto LineDone
00289
00290          goto LineDone
00291
00292          goto LineDone
00293
00294          goto LineDone
00295
00296          goto LineDone
00297
00298          goto LineDone
00299
00300          goto LineDone
00301
00302          goto LineDone
00303
00304          goto LineDone
00305
00306          goto LineDone
00307
00308          goto LineDone
00309
00310          goto LineDone
00311
00312          goto LineDone
00313
00314          goto LineDone
00315
00316          goto LineDone
00317
00318          goto LineDone
00319
00320          goto LineDone
00321
00322          goto LineDone
00323
00324          goto LineDone
00325
00326          goto LineDone
00327
00328          goto LineDone
00329
00330          goto LineDone
00331
00332          goto LineDone
00333
00334          goto LineDone
00335
00336          goto LineDone
00337
00338          goto LineDone
00339
00340          goto LineDone
00341
00342          goto LineDone
00343
00344          goto LineDone
00345
00346          goto LineDone
00347
00348          goto LineDone
00349
00350          goto LineDone
00351
00352          goto LineDone
00353
00354          goto LineDone
00355
00356          goto LineDone
00357
00358          goto LineDone
00359
00360          goto LineDone
00361
00362          goto LineDone
00363
00364          goto LineDone
00365
00366          goto LineDone
00367
00368          goto LineDone
00369
00370          goto LineDone
00371
00372          goto LineDone
00373
00374          goto LineDone
00375
00376          goto LineDone
00377
00378          goto LineDone
00379
00380          goto LineDone
00381
00382          goto LineDone
00383
00384          goto LineDone
00385
00386          goto LineDone
00387
00388          goto LineDone
00389
00390          goto LineDone
00391
00392          goto LineDone
00393
00394          goto LineDone
00395
00396          goto LineDone
00397
00398          goto LineDone
00399
00400          goto LineDone
00401
00402          goto LineDone
00403
00404          goto LineDone
00405
00406          goto LineDone
00407
00408          goto LineDone
00409
00410          goto LineDone
00411
00412          goto LineDone
00413
00414          goto LineDone
00415
00416          goto LineDone
00417
00418          goto LineDone
00419
00420          goto LineDone
00421
00422          goto LineDone
00423
00424          goto LineDone
00425
00426          goto LineDone
00427
00428          goto LineDone
00429
00430          goto LineDone
00431
00432          goto LineDone
00433
00434          goto LineDone
00435
00436          goto LineDone
00437
00438          goto LineDone
00439
00440          goto LineDone
00441
00442          goto LineDone
00443
00444          goto LineDone
00445
00446          goto LineDone
00447
00448          goto LineDone
00449
00450          goto LineDone
00451
00452          goto LineDone
00453
00454          goto LineDone
00455
00456          goto LineDone
00457
00458          goto LineDone
00459
00460          goto LineDone
00461
00462          goto LineDone
00463
00464          goto LineDone
00465
00466          goto LineDone
00467
00468          goto LineDone
00469
00470          goto LineDone
00471
00472          goto LineDone
00473
00474          goto LineDone
00475
00476          goto LineDone
00477
00478          goto LineDone
00479
00480          goto LineDone
00481
00482          goto LineDone
00483
00484          goto LineDone
00485
00486          goto LineDone
00487
00488          goto LineDone
00489
00490          goto LineDone
00491
00492          goto LineDone
00493
00494          goto LineDone
00495
00496          goto LineDone
00497
00498          goto LineDone
00499
00500          goto LineDone
00501
00502          goto LineDone
00503
00504          goto LineDone
00505
00506          goto LineDone
00507
00508          goto LineDone
00509
00510          goto LineDone
00511
00512          goto LineDone
00513
00514          goto LineDone
00515
00516          goto LineDone
00517
00518          goto LineDone
00519
00520          goto LineDone
00521
00522          goto LineDone
00523
00524          goto LineDone
00525
00526          goto LineDone
00527
00528          goto LineDone
00529
00530          goto LineDone
00531
00532          goto LineDone
00533
00534          goto LineDone
00535
00536          goto LineDone
00537
00538          goto LineDone
00539
00540          goto LineDone
00541
00542          goto LineDone
00543
00544          goto LineDone
00545
00546          goto LineDone
00547
00548          goto LineDone
00549
00550          goto LineDone
00551
00552          goto LineDone
00553
00554          goto LineDone
00555
00556          goto LineDone
00557
00558          goto LineDone
00559
00560          goto LineDone
00561
00562          goto LineDone
00563
00564          goto LineDone
00565
00566          goto LineDone
00567
00568          goto LineDone
00569
00570          goto LineDone
00571
00572          goto LineDone
00573
00574          goto LineDone
00575
00576          goto LineDone
00577
00578          goto LineDone
00579
00580          goto LineDone
00581
00582          goto LineDone
00583
00584          goto LineDone
00585
00586          goto LineDone
00587
00588          goto LineDone
00589
00590          goto LineDone
00591
00592          goto LineDone
00593
00594          goto LineDone
00595
00596          goto LineDone
00597
00598          goto LineDone
00599
00600          goto LineDone
00601
00602          goto LineDone
00603
00604          goto LineDone
00605
00606          goto LineDone
00607
00608          goto LineDone
00609
00610          goto LineDone
00611
00612          goto LineDone
00613
00614          goto LineDone
00615
00616          goto LineDone
00617
00618          goto LineDone
00619
00620          goto LineDone
00621
00622          goto LineDone
00623
00624          goto LineDone
00625
00626          goto LineDone
00627
00628          goto LineDone
00629
00630          goto LineDone
00631
00632          goto LineDone
00633
00634          goto LineDone
00635
00636          goto LineDone
00637
00638          goto LineDone
00639
00640          goto LineDone
00641
00642          goto LineDone
00643
00644          goto LineDone
00645
00646          goto LineDone
00647
00648          goto LineDone
00649
00650          goto LineDone
00651
00652          goto LineDone
00653
00654          goto LineDone
00655
00656          goto LineDone
00657
00658          goto LineDone
00659
00660          goto LineDone
00661
00662          goto LineDone
00663
00664          goto LineDone
00665
00666          goto LineDone
00667
00668          goto LineDone
00669
00670          goto LineDone
00671
00672          goto LineDone
00673
00674          goto LineDone
00675
00676          goto LineDone
00677
00678          goto LineDone
00679
00680          goto LineDone
00681
00682          goto LineDone
00683
00684          goto LineDone
00685
00686          goto LineDone
00687
00688          goto LineDone
00689
00690          goto LineDone
00691
00692          goto LineDone
00693
00694          goto LineDone
00695
00696          goto LineDone
00697
00698          goto LineDone
00699
00700          goto LineDone
00701
00702          goto LineDone
00703
00704          goto LineDone
00705
00706          goto LineDone
00707
00708          goto LineDone
00709
00710          goto LineDone
00711
00712          goto LineDone
00713
00714          goto LineDone
00715
00716          goto LineDone
00717
00718          goto LineDone
00719
00720          goto LineDone
00721
00722          goto LineDone
00723
00724          goto LineDone
00725
00726          goto LineDone
00727
00728          goto LineDone
00729
00730          goto LineDone
00731
00732          goto LineDone
00733
00734          goto LineDone
00735
00736          goto LineDone
00737
00738          goto LineDone
00739
00740          goto LineDone
00741
00742          goto LineDone
00743
00744          goto LineDone
00745
00746          goto LineDone
00747
00748          goto LineDone
00749
00750          goto LineDone
00751
00752          goto LineDone
00753
00754          goto LineDone
00755
00756          goto LineDone
00757
00758          goto LineDone
00759
00760          goto LineDone
00761
00762          goto LineDone
00763
00764          goto LineDone
00765
00766          goto LineDone
00767
00768          goto LineDone
00769
00770          goto LineDone
00771
00772          goto LineDone
00773
00774          goto LineDone
00775
00776          goto LineDone
00777
00778          goto LineDone
00779
00780          goto LineDone
00781
00782          goto LineDone
00783
00784          goto LineDone
00785
00786          goto LineDone
00787
00788          goto LineDone
00789
00790          goto LineDone
00791
00792          goto LineDone
00793
00794          goto LineDone
00795
00796          goto LineDone
00797
00798          goto LineDone
00799
00800          goto LineDone
00801
00802          goto LineDone
00803
00804          goto LineDone
00805
00806          goto LineDone
00807
00808          goto LineDone
00809
00810          goto LineDone
00811
00812          goto LineDone
00813
00814          goto LineDone
00815
00816          goto LineDone
00817
00818          goto LineDone
00819
00820          goto LineDone
00821
00822          goto LineDone
00823
00824          goto LineDone
00825
00826          goto LineDone
00827
00828          goto LineDone
00829
00830          goto LineDone
00831
00832          goto LineDone
00833
00834          goto LineDone
00835
00836          goto LineDone
00837
00838          goto LineDone
00839
00840          goto LineDone
00841
00842          goto LineDone
00843
00844          goto LineDone
00845
00846          goto LineDone
00847
00848          goto LineDone
00849
00850          goto LineDone
00851
00852          goto LineDone
00853
00854          goto LineDone
00855
00856          goto LineDone
00857
00858          goto LineDone
00859
00860          goto LineDone
00861
00862          goto LineDone
00863
00864          goto LineDone
00865
00866          goto LineDone
00867
00868          goto LineDone
00869
00870          goto LineDone
00871
00872          goto LineDone
00873
00874          goto LineDone
00875
00876          goto LineDone
00877
00878          goto LineDone
00879
00880          goto LineDone
00881
00882          goto LineDone
00883
00884          goto LineDone
00885
00886          goto LineDone
00887
00888          goto LineDone
00889
00890          goto LineDone
00891
00892          goto LineDone
00893
00894          goto LineDone
00895
00896          goto LineDone
00897
00898          goto LineDone
00899
00900          goto LineDone
00901
00902          goto LineDone
00903
00904          goto LineDone
00905
00906          goto LineDone
00907
00908          goto LineDone
00909
00910          goto LineDone
00911
00912          goto LineDone
00913
00914          goto LineDone
00915
00916          goto LineDone
00917
00918          goto LineDone
00919
00920          goto LineDone
00921
00922          goto LineDone
00923
00924          goto LineDone
00925
00926          goto LineDone
00927
00928          goto LineDone
00929
00930          goto LineDone
00931
00932          goto LineDone
00933
00934          goto LineDone
00935
00936          goto LineDone
00937
00938          goto LineDone
00939
00940          goto LineDone
00941
00942          goto LineDone
00943
00944          goto LineDone
00945
00946          goto LineDone
00947
00948          goto LineDone
00949
00950          goto LineDone
00951
00952          goto LineDone
00953
00954          goto LineDone
00955
00956          goto LineDone
00957
00958          goto LineDone
00959
00960          goto LineDone
00961
00962          goto LineDone
00963
00964          goto LineDone
00965
00966          goto LineDone
00967
00968          goto LineDone
00969
00970          goto LineDone
00971
00972          goto LineDone
00973
00974          goto LineDone
00975
00976          goto LineDone
00977
00978          goto LineDone
00979
00980          goto LineDone
00981
00982          goto LineDone
00983
00984          goto LineDone
00985
00986          goto LineDone
00987
00988          goto LineDone
00989
00990          goto LineDone
00991
00992          goto LineDone
00993
00994          goto LineDone
00995
00996          goto LineDone
00997
00998          goto LineDone
00999
01000          goto LineDone

```

```

00206 ;-----
00207 ;Get data bytes and checksum from line of hex file
00208
00209          movlw   dataArray
00210          movwf   FSR           ;set pointer to start of array
00211          movf   NumWords,W
00212          movwf  Counter      ;set counter to number of words
00213
00214 GetData: call   GetHexByte      ;get low data byte
00215          movwf  INDF          ;save in array
00216          incf   FSR,F        ;point to high byte
00217
00218          call   GetHexByte      ;get high data byte
00219          movwf  INDF          ;save in array
00220          incf   FSR,F        ;point to next low byte
00221
00222          decfsz Counter,F
00223          goto   GetData
00224
00225          call   GetHexByte      ;get checksum
00226          movf   Checksum,W    ;check if checksum correct
00227          btfsz STATUS,Z
00228          goto   ErrorMessage
00229
00230          bsf    PORTB,RTS_OUTPUT ;set RTS off to stop data being received
00231
00232 ;-----
00233 ;Get saved data one word at a time to program into flash
00234
00235          movlw   dataArray
00236          movwf   FSR           ;point to start of array
00237          movf   NumWords,W
00238          movwf  Counter      ;set counter to half number of bytes
00239
00240 ;-----
00241 ;Check if address is in reset code area
00242
00243 CheckAddress: movf   AddressH,W ;checking for boot location code
00244             btfsz  STATUS,Z    ;test if AddressH is zero
00245             goto   CheckAddress1 ;if not go check if reset code received
00246
00247             movlw  0xfc
00248             addwf  AddressL,W    ;add 0xfc (-4) to address
00249             btfsz  STATUS,C    ;no carry means address < 4
00250             goto   CheckAddress1 ;if not go check if reset code received
00251
00252             bsf    TestByte,0   ;show that reset vector code received

```

```

1F7C 0821      movf   AddressL,W      ;relocate addresses 0-3 to new location
1F7D 3E24      addlw  low (StartUserCode + 1) ;add low address to new location
1F80 008D      movwf  EEADR          ;change from bank0 to bank2
1F81 301F      movlw  high (StartUserCode + 1) ;get new location high address
1F82 008F      movwf  EEADRH         ;load high address
1F83 2F9A      goto   LoadData      ;go get data byte and program into flash
00253 00261 ;-----
00254 00262 ;Check if reset code has been received
00255 00263 ;Check if address is too high and conflicts with boot loader
00256 00264
00257 00265 CheckAddress1: btfss  TestByte,0      ;check if reset vector code received first
00258 00266          goto   ErrorMessage      ;if not then error
00259 00267
00260 00268          movlw  high StartOfBoot ;get high byte of address
00261 00269          subwf  AddressH,W
00262 00270          btfss  STATUS,C      ;test if less than boot code address
00263 00271          goto   LoadAddress    ;yes so continue with write
00264 00272          btfss  STATUS,Z      ;test if equal to boot code address
00265 00273          goto   ErrorMessage    ;no so error in high byte of address
00266 00274
00267 00275          movlw  low StartOfBoot ;get low byte of address
00268 00276          subwf  AddressL,W
00269 00277          btfsc  STATUS,C      ;test if less than boot code address
00270 00278          goto   ErrorMessage    ;no so error in address
00271 00279
00272 ;-----
00273 ;Load address and data and write data into flash
00274 ;-----
00275 ;-----
00276 ;-----
00277 ;-----
00278 ;-----
00279 ;-----
00280 ;-----
00281 ;Load address and data and write data into flash
00282 ;-----
00283 LoadAddress:  movf   AddressH,W      ;get high address
00284          Bank2      ;change from bank0 to bank2
00285          movwf  EEADRH         ;load high address
00286          Bank0      ;change from bank2 to bank0
00287          movf   AddressL,W      ;get low address
00288          Bank2      ;change from bank0 to bank2
00289          movwf  EEADR          ;load low address
00290
00291 LoadData:     movf   INDF,W      ;get low byte from array
00292          movwf  EEDATA         ;load low byte
00293          incf   FSR,F          ;point to high data byte
00294          movf   INDF,W      ;get high byte from array
00295          movwf  EEDATH         ;load high byte
00296          incf   FSR,F          ;point to next low data byte
00297
00298          call   FlashWrite     ;write data to program memory
00299

```



```

00300      Bank0      ;change from bank3 to bank0
00301      incfsz   AddressL,F ;increment low address byte
00302      goto     CheckLineDone ;check for rollover
00303      incf    AddressH,F ;if so then increment high address byte
00304
00305      CheckLineDone: decfsz Counter,F ;check if all words have been programmed
00306      goto     CheckAddress ;if not then go program next word
00307
00308      ;-----
00309      ;Done programming line of file
00310
00311      LineDone:  movlw   '.' ;line has been programmed so
00312      call     SerialTransmit ;transmit progress indicator back
00313      goto     GetNewLine ;go get next line hex file
00314
00315      ;-----
00316      ;Done programming file so send success indicator and trap execution until reset
00317
00318      FileDone:  movlw   'S' ;programming complete so
00319      call     SerialTransmit ;transmit success indicator back
00320
00321      call     LoadStatusAddr ;load address of CodeStatus word
00322      clrf    EEDATH ;load data to indicate program exists
00323      clrf    EEDATA ;load data to indicate program exists
00324      call     FlashWrite
00325      TrapFileDone: goto   TrapFileDone ;all done so wait for reset
00326
00327      ;-----
00328      ;Error in hex file so send failure indicator and trap error
00329
00330      ErrorMessage: movlw   'F' ;error occurred so
00331      call     SerialTransmit ;transmit failure indicator back
00332      TrapError3:  goto     TrapError3 ;trap error and wait for reset
00333
00334      ;-----
00335      ;Load address of CodeStatus word into flash memory address registers
00336      ;This routine returns in bank2
00337
00338      LoadStatusAddr: Bank2
00339      movlw   high CodeStatus ;load high addr of CodeStatus location
00340      movwf  EEADRH
00341      movlw   low CodeStatus ;load low addr of CodeStatus location
00342      movwf  EEADR
00343      return
00344
00345      ;-----
00346      ;Receive two ascii digits and convert into one hex byte

```

```

00347 ;This routine returns in bank0
00348
1FBC 27DB      call   SerialReceive      ;get new byte from serial port
1FBD 3EBF      addlw  0xbf                ;add -'A' to Ascii high byte
1FBE 1C03      btfs   STATUS,C           ;check if positive
1FEF 3E07      addlw  0x07                ;if not, add 17 ('0' to '9')
1FC0 3E0A      addlw  0x0a                ;else add 10 ('A' to 'F')
1F01 00A6      movwf  HexByte            ;save nibble
1FC2 0EA6      swapf  HexByte,F         ;move nibble to high position
00356
1FC3 27DB      call   SerialReceive      ;get new byte from serial port
1FC4 3EBF      addlw  0xbf                ;add -'A' to Ascii low byte
1FC5 1C03      btfs   STATUS,C           ;check if positive
1FC6 3E07      addlw  0x07                ;if not, add 17 ('0' to '9')
1FC7 3E0A      addlw  0x0a                ;else add 10 ('A' to 'F')
1FC8 04A6      iorwf  HexByte,F         ;add low nibble to high nibble
1FC9 0826      movf   HexByte,W         ;put result in W reg
1FCA 07A3      addwf  Checksum,F        ;add to cumulative checksum
1FCB 0008      return
00366
00367 ;-----
00368 ;Set up USART for asynchronous comms
00369 ;Routine is only called once and can be placed in-line saving a call and return
00370 ;This routine returns in bank0
00371
00372 SerialSetup:  Bank0      ;change from bank3 to bank0
00373                bsf     PORTB,RTS_OUTPUT ;set RTS off before setting as output
00374                Bank1      ;change from bank0 to bank1
00375                bcf     TRISB,RTS_OUTPUT ;enable RTS pin as output
00376                movlw   BAUD_CONSTANT ;set baud rate 9600 for 4Mhz clock
00377                movwf  SPBRG
00378                bsf     TXSTA,BRGH    ;baud rate high speed option
00379                bsf     TXSTA,TXEN    ;enable transmission
00380                Bank0      ;change from bank1 to bank0
00381                bsf     RCSTA,CREN    ;enable reception
00382                bsf     RCSTA,SPEN    ;enable serial port
00383                return
00384
00385 ;-----
00386 ;Wait for byte to be received in USART and return with byte in W
00387 ;This routine returns in bank0
00388
00389 SerialReceive: Bank0      ;change from unknown bank to bank0
00390                bcf     PORTB,RTS_OUTPUT ;set RTS on for data to be received
00391                btfs   PIR1,RCIF      ;check if data received
00392                goto   $-1            ;wait until new data
00393                movf   RCREG,W        ;get received data into W

```

```

1FE1 0008          return
00394          return
00395
00396 ;-----
00397 ;Transmit byte in W register from USART
00398 ;This routine returns in bank0
00399
00400 SerialTransmit: Bank0          ;change from unknown bank to bank0
00401      btfsc PORTB,CTS_INPUT      ;check CTS to see if data can be sent
00402      goto  $-1
00403      btfss PIR1,TXIF            ;check that buffer is empty
00404      goto  $-1
00405      movwf TXREG                ;transmit byte
00406      return
00407
00408 ;-----
00409 ;Write to a location in the flash program memory
00410 ;Address in EEADRH and EEADR, data in EEDATH and EEDATA
00411 ;This routine returns in bank3
00412
00413 FlashWrite: Bank3
00414      movlw 0x84                  ;change from bank2 to bank3
00415      movwf EECON1                ;enable writes to program flash
00416
00417      movlw 0x55                  ;do timed access writes
00418      movwf EECON2
00419      movlw 0xaa
00420      movwf EECON2
00421      bsf  EECON1,WR              ;begin writing to flash
00422
00423      nop
00424      nop
00425      return
00426
00427 ;-----
00428 ;Read from a location in the flash program memory
00429 ;Address is in EEADRH and EEADR, data returned in EEDATH and EEDATA
00430 ;Routine is only called once and can be placed in-line saving a call and return
00431 ;This routine returns in bank3 and is called when in bank2
00432
00433 FlashRead:  movlw 0x1f          ;keep address within range
00434            andwf EEADRH,F
00435
00436      Bank3
00437      movlw 0x80
00438      movwf EECON1                ;change from bank2 to bank3
00439                                     ;enable reads from program flash
00440      bsf  EECON1,RD              ;read from flash

```

```
1FFD 0000          ;processor waits while reading
1FFE 0000          nop
1FFF 0008          nop
0041          return
0042          ;
0043          ;
0044          ;
0045          ;
0046          ;
0047          ;
0048          ;
```

MEMORY USAGE MAP ('X' = Used, '-' = Unused)

```
0000 : XXX-----
1F00 : -----XXXXXXXXXXXXXXXXXXXXXXXXXXXX
1F40 : XXXXXXXXXXXXXXXX XXXXXXXXXXXXXXXX XXXXXXXXXXXXXXXX XXXXXXXXXXXXXXXX
1F80 : XXXXXXXXXXXXXXXX XXXXXXXXXXXXXXXX XXXXXXXXXXXXXXXX XXXXXXXXXXXXXXXX
1FC0 : XXXXXXXXXXXXXXXX XXXXXXXXXXXXXXXX XXXXXXXXXXXXXXXX XXXXXXXXXXXXXXXX
2000 : -----X-----
```

All other memory blocks unused.

Program Memory Words Used: 227
Program Memory Words Free: 7965

Errors : 0
Warnings : 0 reported, 0 suppressed
Messages : 1 reported, 24 suppressed

APPENDIX B: HEX FILE FORMAT

MPASM generates an 8-bit Intel hex file (INHX8M) by default. The lines of this hex file all have the following format:

```
:BBAAAATTHHHH...HHCC
```

A colon precedes each line and is followed by hexadecimal digits in ASCII format.

BB is a 2-digit hexadecimal byte count representing the number of data bytes that will appear on the line. This is a number from 0x00 to 0x10 and is always even because the PIC16F87X parts have a 14-bit wide memory and use two bytes for every program memory word.

AAAA is a 4-digit hexadecimal address representing the starting byte address of the data bytes that follow. To get the actual program memory word address, the byte address must be divided by two.

TT is a 2-digit hexadecimal record type that indicates the meaning of the data on the line. It is 0x00 for a regular data record and 0x01 for an end of file record. The boot code ignores all other record types.

HH are 2-digit hexadecimal data bytes that correspond to addresses, incrementing sequentially from the starting address earlier in the line. These bytes come in low byte, high byte pairs, corresponding to each 14-bit program memory word.

CC is a 2-digit hexadecimal checksum byte, such that the sum of all bytes in the line including the checksum, is a multiple of 256. The initial colon is ignored.

The code in Example B-1 will generate a line in a hex file as shown in Figure B-1.

EXAMPLE B-1: CODE TO GENERATE A HEX FILE

```

ORG          0x17A

movlw       0xFF
movwf       PORTB
bsf         STATUS, RP0
movwf       TRISA
clrf        TRISB
bcf         STATUS, RP0
    
```

FIGURE B-1: LINE OF HEX FILE

```
:0C02F400FF30860083168500860183120F
```

Checksum is 0x0F

$$\begin{aligned}
 &0x0C + 0x02 + 0xF4 + 0x00 + 0xFF + 0x30 + \\
 &0x86 + 0x00 + 0x83 + 0x16 + 0x85 + 0x00 + \\
 &0x86 + 0x01 + 0x83 + 0x12 + 0x0F = 0x0500
 \end{aligned}$$

Result of addition⁽¹⁾ mod 256 is zero

Second program memory word is 0x0086

This corresponds to an instruction MOVWF 0x06⁽²⁾

First program memory word is 0x30FF

This corresponds to an instruction MOVLW 0xFF

Record type is 0x00 indicating a regular data record

Address of first program memory word is $0x02F4 \div 2 = 0x017A$

Number of data bytes is 0x0C

Number of program memory words is $0x0C \div 2 = 0x06$

Note 1: The calculation to test the checksum adds every byte (pair of digits) in the line of the hex file, including the checksum itself.

2: The label PORTB is defined as 0x06 in the standard include file for the PIC16F877.

APPENDIX C: RS-232 HARDWARE HANDSHAKING SIGNALS

Understanding hardware flow control can be confusing, because of the terminology used and the slightly different way that handshaking is now implemented, compared to the original specification.

RS-232 hardware handshaking was specified in terms of communication between Data Terminal Equipment (DTE) and Data Communications Equipment (DCE). The DTE (e.g., computer terminal) was always faster than the DCE (e.g., modem) and could receive data without interruption. The hardware handshaking protocol required that the DTE would request to send data to the DCE (with the request to send RTS signal) and that the DCE would then indicate to the DTE that it was cleared to send data (with the clear to send CTS signal). Both RTS and CTS were, therefore, used to control data flow from the DTE to the DCE.

The Data Terminal Ready (DTR) signal was defined so that the DTE could indicate to the DCE that it was attached and ready to communicate. The Data Set Ready (DSR) signal was defined to enable the DCE to indicate to the DTE that it was attached and ready to communicate. These are higher level signals not generally used for byte by byte control of data flow, although they can be used for this purpose.

Most RS-232 connections use 9-pin DSUB connectors. A DTE uses a male connector and a DCE uses a female connector. The signal names are always in terms of the DTE, so the RTS pin on the female connector of the DCE is an input and is the RTS signal from the DTE.

Over time, the clear distinction between the DTE and DCE has been lost. In many instances, two DTE devices are connected together. In other cases, the DCE device is able to send data at a rate that is too high for the DTE to receive continuously. In practice, the DTR output of the DTE has come to be used to control the flow of data to the DTE and now indicates that the DCE (or other DTE) may send data. It no longer indicates a request to send data to the DCE.

It is common for a DTE to be connected to another DTE (e.g., two computers), and in this case, they will both have male connectors and the cable between them will have two female connectors. This is known as a null modem cable. The cable is usually wired in such a way that each DTE looks like a DCE to the other DTE. To achieve this, the RTS output of one DTE is connected to the CTS input of the other DTE and vice versa. Each DTE device will use its RTS output to allow the other DTE device to transmit data and will check its CTS input to determine whether it is allowed to transmit data.

FIGURE C-1: DTE TO DCE CONNECTION

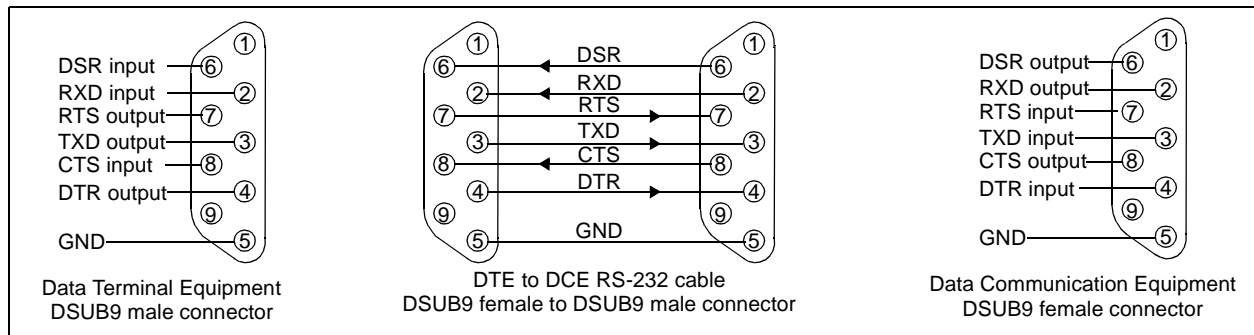
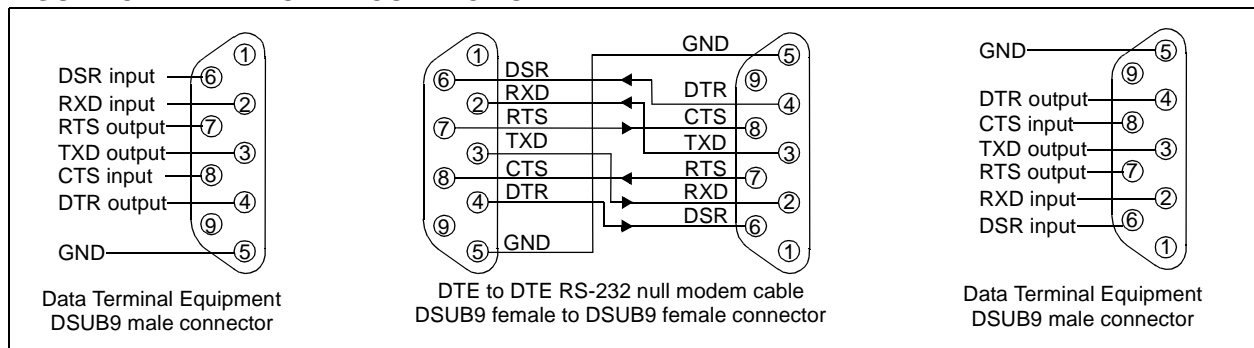

FIGURE C-2: DTE TO DTE CONNECTION



Note the following details of the code protection feature on PICmicro® MCUs.

- The PICmicro family meets the specifications contained in the Microchip Data Sheet.
- Microchip believes that its family of PICmicro microcontrollers is one of the most secure products of its kind on the market today, when used in the intended manner and under normal conditions.
- There are dishonest and possibly illegal methods used to breach the code protection feature. All of these methods, to our knowledge, require using the PICmicro microcontroller in a manner outside the operating specifications contained in the data sheet. The person doing so may be engaged in theft of intellectual property.
- Microchip is willing to work with the customer who is concerned about the integrity of their code.
- Neither Microchip nor any other semiconductor manufacturer can guarantee the security of their code. Code protection does not mean that we are guaranteeing the product as “unbreakable”.
- Code protection is constantly evolving. We at Microchip are committed to continuously improving the code protection features of our product.

If you have any further questions about this matter, please contact the local sales office nearest to you.

Information contained in this publication regarding device applications and the like is intended through suggestion only and may be superseded by updates. It is your responsibility to ensure that your application meets with your specifications. No representation or warranty is given and no liability is assumed by Microchip Technology Incorporated with respect to the accuracy or use of such information, or infringement of patents or other intellectual property rights arising from such use or otherwise. Use of Microchip's products as critical components in life support systems is not authorized except with express written approval by Microchip. No licenses are conveyed, implicitly or otherwise, under any intellectual property rights.

Trademarks

The Microchip name and logo, the Microchip logo, FilterLab, KEELOQ, microID, MPLAB, PIC, PICmicro, PICMASTER, PICSTART, PRO MATE, SEEVAL and The Embedded Control Solutions Company are registered trademarks of Microchip Technology Incorporated in the U.S.A. and other countries.

dsPIC, ECONOMONITOR, FanSense, FlexROM, fuzzyLAB, In-Circuit Serial Programming, ICSP, ICEPIC, microPort, Migratable Memory, MPASM, MPLIB, MPLINK, MPSIM, MXDEV, PICC, PICDEM, PICDEM.net, rPIC, Select Mode and Total Endurance are trademarks of Microchip Technology Incorporated in the U.S.A.

Serialized Quick Turn Programming (SQTP) is a service mark of Microchip Technology Incorporated in the U.S.A.

All other trademarks mentioned herein are property of their respective companies.

© 2002, Microchip Technology Incorporated, Printed in the U.S.A., All Rights Reserved.

 Printed on recycled paper.



Microchip received QS-9000 quality system certification for its worldwide headquarters, design and wafer fabrication facilities in Chandler and Tempe, Arizona in July 1999. The Company's quality system processes and procedures are QS-9000 compliant for its PICmicro® 8-bit MCUs, KEELOQ® code hopping devices, Serial EEPROMs and microperipheral products. In addition, Microchip's quality system for the design and manufacture of development systems is ISO 9001 certified.



MICROCHIP

WORLDWIDE SALES AND SERVICE

AMERICAS

Corporate Office

2355 West Chandler Blvd.
Chandler, AZ 85224-6199
Tel: 480-792-7200 Fax: 480-792-7277
Technical Support: 480-792-7627
Web Address: <http://www.microchip.com>

Rocky Mountain

2355 West Chandler Blvd.
Chandler, AZ 85224-6199
Tel: 480-792-7966 Fax: 480-792-7456

Atlanta

500 Sugar Mill Road, Suite 200B
Atlanta, GA 30350
Tel: 770-640-0034 Fax: 770-640-0307

Boston

2 Lan Drive, Suite 120
Westford, MA 01886
Tel: 978-692-3848 Fax: 978-692-3821

Chicago

333 Pierce Road, Suite 180
Itasca, IL 60143
Tel: 630-285-0071 Fax: 630-285-0075

Dallas

4570 Westgrove Drive, Suite 160
Addison, TX 75001
Tel: 972-818-7423 Fax: 972-818-2924

Detroit

Tri-Atria Office Building
32255 Northwestern Highway, Suite 190
Farmington Hills, MI 48334
Tel: 248-538-2250 Fax: 248-538-2260

Kokomo

2767 S. Albright Road
Kokomo, Indiana 46902
Tel: 765-864-8360 Fax: 765-864-8387

Los Angeles

18201 Von Karman, Suite 1090
Irvine, CA 92612
Tel: 949-263-1888 Fax: 949-263-1338

New York

150 Motor Parkway, Suite 202
Hauppauge, NY 11788
Tel: 631-273-5305 Fax: 631-273-5335

San Jose

Microchip Technology Inc.
2107 North First Street, Suite 590
San Jose, CA 95131
Tel: 408-436-7950 Fax: 408-436-7955

Toronto

6285 Northam Drive, Suite 108
Mississauga, Ontario L4V 1X5, Canada
Tel: 905-673-0699 Fax: 905-673-6509

ASIA/PACIFIC

Australia

Microchip Technology Australia Pty Ltd
Suite 22, 41 Rawson Street
Epping 2121, NSW
Australia
Tel: 61-2-9868-6733 Fax: 61-2-9868-6755

China - Beijing

Microchip Technology Consulting (Shanghai)
Co., Ltd., Beijing Liaison Office
Unit 915
Bei Hai Wan Tai Bldg.
No. 6 Chaoyangmen Beidajie
Beijing, 100027, No. China
Tel: 86-10-85282100 Fax: 86-10-85282104

China - Chengdu

Microchip Technology Consulting (Shanghai)
Co., Ltd., Chengdu Liaison Office
Rm. 2401, 24th Floor,
Ming Xing Financial Tower
No. 88 TIDU Street
Chengdu 610016, China
Tel: 86-28-6766200 Fax: 86-28-6766599

China - Fuzhou

Microchip Technology Consulting (Shanghai)
Co., Ltd., Fuzhou Liaison Office
Unit 28F, World Trade Plaza
No. 71 Wusi Road
Fuzhou 350001, China
Tel: 86-591-7503506 Fax: 86-591-7503521

China - Shanghai

Microchip Technology Consulting (Shanghai)
Co., Ltd.
Room 701, Bldg. B
Far East International Plaza
No. 317 Xian Xia Road
Shanghai, 200051
Tel: 86-21-6275-5700 Fax: 86-21-6275-5060

China - Shenzhen

Microchip Technology Consulting (Shanghai)
Co., Ltd., Shenzhen Liaison Office
Rm. 1315, 13/F, Shenzhen Kerry Centre,
Renminnan Lu
Shenzhen 518001, China
Tel: 86-755-2350361 Fax: 86-755-2366086

Hong Kong

Microchip Technology Hongkong Ltd.
Unit 901-6, Tower 2, Metroplaza
223 Hing Fong Road
Kwai Fong, N.T., Hong Kong
Tel: 852-2401-1200 Fax: 852-2401-3431

India

Microchip Technology Inc.
India Liaison Office
Divyasree Chambers
1 Floor, Wing A (A3/A4)
No. 11, O'Shaugnessey Road
Bangalore, 560 025, India
Tel: 91-80-2290061 Fax: 91-80-2290062

Japan

Microchip Technology Japan K.K.
Benex S-1 6F
3-18-20, Shinyokohama
Kohoku-Ku, Yokohama-shi
Kanagawa, 222-0033, Japan
Tel: 81-45-471-6166 Fax: 81-45-471-6122

Korea

Microchip Technology Korea
168-1, Youngbo Bldg. 3 Floor
Samsung-Dong, Kangnam-Ku
Seoul, Korea 135-882
Tel: 82-2-554-7200 Fax: 82-2-558-5934

Singapore

Microchip Technology Singapore Pte Ltd.
200 Middle Road
#07-02 Prime Centre
Singapore, 188980
Tel: 65-334-8870 Fax: 65-334-8850

Taiwan

Microchip Technology Taiwan
11F-3, No. 207
Tung Hua North Road
Taipei, 105, Taiwan
Tel: 886-2-2717-7175 Fax: 886-2-2545-0139

EUROPE

Denmark

Microchip Technology Nordic ApS
Regus Business Centre
Lautrup høj 1-3
Ballerup DK-2750 Denmark
Tel: 45 4420 9895 Fax: 45 4420 9910

France

Microchip Technology SARL
Parc d'Activite du Moulin de Massy
43 Rue du Saule Trapu
Batiment A - 1er Etage
91300 Massy, France
Tel: 33-1-69-53-63-20 Fax: 33-1-69-30-90-79

Germany

Microchip Technology GmbH
Gustav-Heinemann Ring 125
D-81739 Munich, Germany
Tel: 49-89-627-144 0 Fax: 49-89-627-144-44

Italy

Microchip Technology SRL
Centro Direzionale Colleoni
Palazzo Taurus 1 V. Le Colleoni 1
20041 Agrate Brianza
Milan, Italy
Tel: 39-039-65791-1 Fax: 39-039-6899883

United Kingdom

Arizona Microchip Technology Ltd.
505 Eskdale Road
Winnersh Triangle
Wokingham
Berkshire, England RG41 5TU
Tel: 44 118 921 5869 Fax: 44-118 921-5820

01/18/02