

# TLC540I, TLC541I 8-BIT ANALOG-TO-DIGITAL CONVERTERS WITH SERIAL CONTROL AND 11 INPUTS

SLAS065A – OCTOBER 1983 – REVISED MARCH 1995

- 8-Bit Resolution A/D Converter
- Microprocessor Peripheral or Stand-Alone Operation
- On-Chip 12-Channel Analog Multiplexer
- Built-in Self-Test Mode
- Software-Controllable Sample and Hold
- Total Unadjusted Error . . .  $\pm 0.5$  LSB Max
- TLC541 is Direct Replacement for Motorola MC145040 and National Semiconductor ADC0811. TLC540 is Capable of Higher Speed
- Pinout and Control Signals Compatible with TLC1540 Family of 10-Bit A/D Converters
- CMOS Technology

PARAMETER	TLC540	TLC541
Channel Acquisition Sample Time	2 $\mu$ s	3.6 $\mu$ s
Conversion Time (Max)	9 $\mu$ s	17 $\mu$ s
Samples per Second (Max)	75 x 10 <sup>3</sup>	40 x 10 <sup>3</sup>
Power Dissipation (Max)	12.5 mW	12.5 mW

## description

The TLC540 and TLC541 are CMOS A/D converters built around an 8-bit switched-capacitor successive-approximation A/D converters. They are designed for serial interface to a microprocessor or peripheral via a 3-state output with up to four control inputs, including independent SYSTEM CLOCK, I/O CLOCK, chip select (CS), and ADDRESS INPUT. A 4-MHz system clock for the TLC540 and a 2.1-MHz system clock for the TLC541 with a design that

includes simultaneous read/write operation allow high-speed data transfers and sample rates of up to 75,180 samples per second for the TLC540 and 40,000 samples per second for the TLC541. In addition to the high-speed converter and versatile control logic, there is an on-chip 12-channel analog multiplexer that can be used to sample any one of 11 inputs or an internal self-test voltage, and a sample-and-hold that can operate automatically or under microprocessor control. Detailed information on interfacing to most popular microprocessors is readily available from the factory.

DW OR N PACKAGE  
(TOP VIEW)

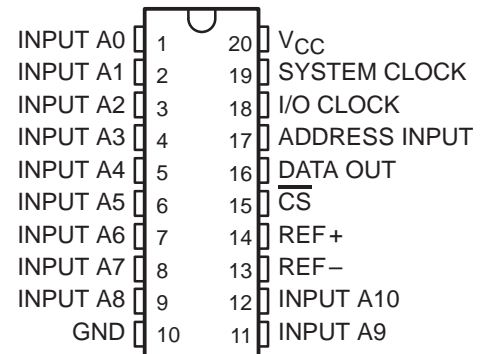

FN PACKAGE  
(TOP VIEW)

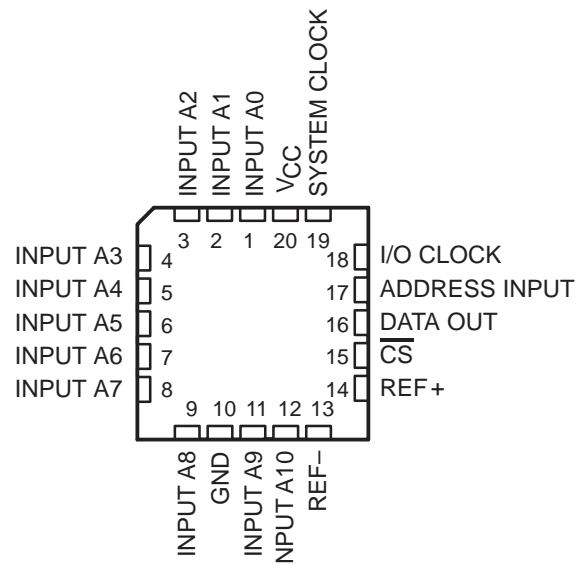

## AVAILABLE OPTIONS

T <sub>A</sub>	PACKAGE		
	SO PLASTIC DIP (DW)	PLASTIC DIP (N)	CHIP CARRIER (FN)
-40°C to 85°C	— TLC541IDW	TLC540IN TLC541IN	TLC540IFN TLC541IFN
-55°C to 125°C	—	TLC541MN	—

PRODUCTION DATA information is current as of publication date. Products conform to specifications per the terms of Texas Instruments standard warranty. Production processing does not necessarily include testing of all parameters.



POST OFFICE BOX 655303 • DALLAS, TEXAS 75265

Copyright © 1995, Texas Instruments Incorporated

# TLC540I, TLC541I 8-BIT ANALOG-TO-DIGITAL CONVERTERS WITH SERIAL CONTROL AND 11 INPUTS

SLAS065A – OCTOBER 1983 – REVISED MARCH 1995

The converters incorporated in the TLC540 and TLC541 feature differential high-impedance reference inputs that facilitate ratiometric conversion, scaling, and analog circuitry isolation from logic and supply noises. A switched-capacitor design allows low-error ( $\pm 0.5$  LSB) conversion in  $9 \mu\text{s}$  for the TLC540 and  $17 \mu\text{s}$  for the TLC541 over the full operating temperature range.

The TLC540I and TLC541I are characterized for operation from  $-40^{\circ}\text{C}$  to  $85^{\circ}\text{C}$ . The TLC541M is characterized for operation from  $-55^{\circ}\text{C}$  to  $125^{\circ}\text{C}$ .

## functional block diagram

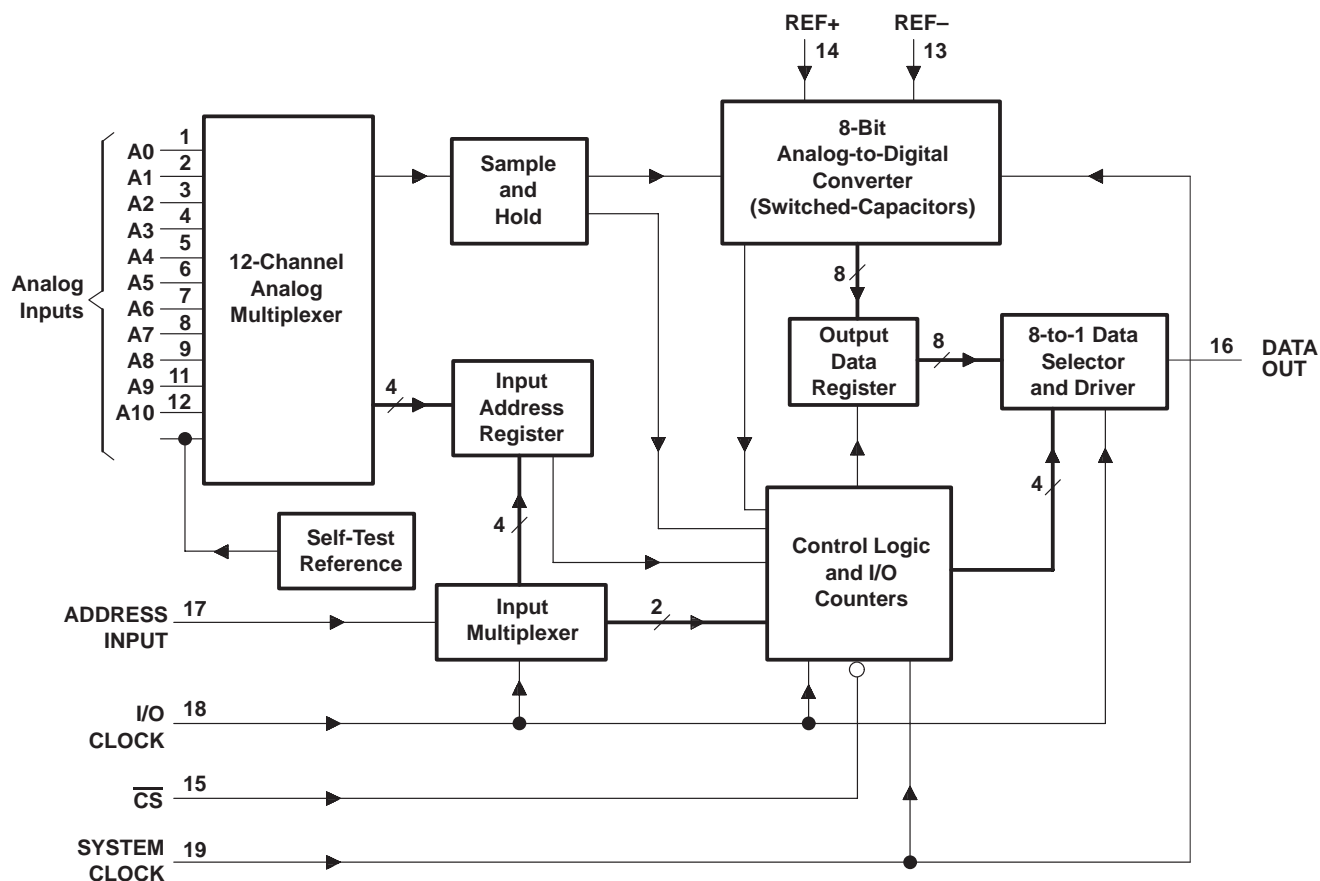

## typical equivalent inputs

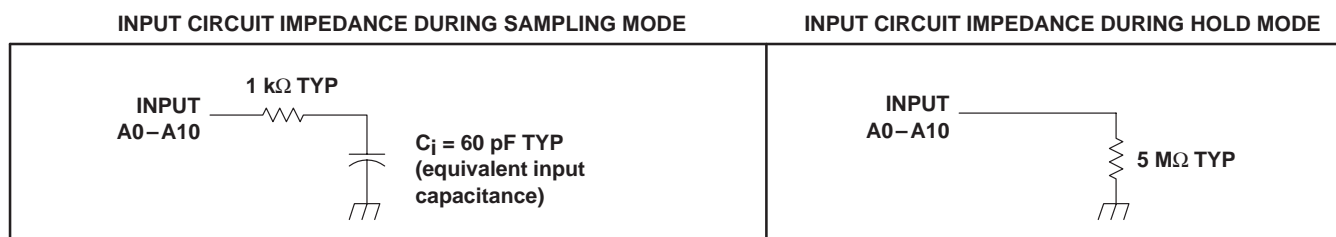

**TLC5401, TLC5411**  
**8-BIT ANALOG-TO-DIGITAL CONVERTERS**  
**WITH SERIAL CONTROL AND 11 INPUTS**

SLAS065A – OCTOBER 1983 – REVISED MARCH 1995

**operating sequence**

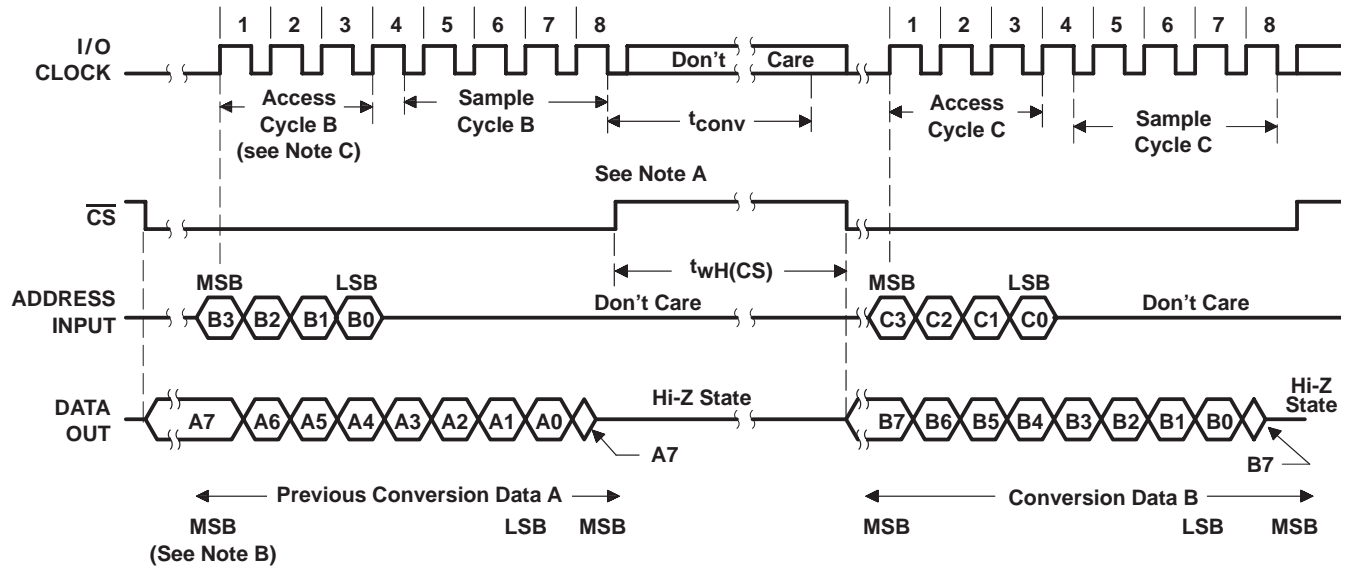

- NOTES: A. The conversion cycle, which requires 36 system clock periods, is initiated on the 8th falling edge of I/O CLOCK after  $\overline{CS}$  goes low for the channel whose address exists in memory at that time. If  $\overline{CS}$  is kept low during conversion, I/O CLOCK must remain low for at least 36 system clock cycles to allow conversion to be completed.
- B. The most significant bit (MSB) will automatically be placed on the DATA OUT bus after  $\overline{CS}$  is brought low. The remaining seven bits (A6–A0) will be clocked out on the first seven I/O CLOCK falling edges.
- C. To minimize errors caused by noise at  $\overline{CS}$ , the internal circuitry waits for three system clock cycles (or less) after a chip select falling edge is detected before responding to control input signals. Therefore, no attempt should be made to clock-in address data until the minimum chip-select setup time has elapsed.

**absolute maximum ratings over operating free-air temperature range (unless otherwise noted)†**

Supply voltage, $V_{CC}$ (see Note 1)	6.5 V
Input voltage range, $V_I$ (any input)	–0.3 V to $V_{CC} + 0.3$ V
Output voltage range, $V_O$	–0.3 V to $V_{CC} + 0.3$ V
Peak input current range (any input)	±10 mA
Peak total input current (all inputs)	±30 mA
Operating free-air temperature range, $T_A$ : TLC5401, TLC5411	–40°C to 85°C
Storage temperature range, $T_{stg}$	–65°C to 150°C
Case temperature for 10 seconds: FN package	260°C
Lead temperature 1,6 mm (1/16 inch) from case for 10 seconds: DW or N package	260°C

† Stresses beyond those listed under “absolute maximum ratings” may cause permanent damage to the device. These are stress ratings only, and functional operation of the device at these or any other conditions beyond those indicated under “recommended operating conditions” is not implied. Exposure to absolute-maximum-rated conditions for extended periods may affect device reliability.

NOTE 1: All voltage values are with respect to digital ground with REF– and GND wired together (unless otherwise noted).



# TLC540I, TLC541I

## 8-BIT ANALOG-TO-DIGITAL CONVERTERS

### WITH SERIAL CONTROL AND 11 INPUTS

SLAS065A – OCTOBER 1983 – REVISED MARCH 1995

#### recommended operating conditions

	TLC540			TLC541			UNIT	
	MIN	NOM	MAX	MIN	NOM	MAX		
Supply voltage, $V_{CC}$	4.75	5	5.5	4.75	5	5.5	V	
Positive reference voltage, $V_{ref+}$ (see Note 2)	2.5	$V_{CC}$	$V_{CC}+0.1$	2.5	$V_{CC}$	$V_{CC}+0.1$	V	
Negative reference voltage, $V_{ref-}$ (see Note 2)	-0.1	0	2.5	-0.1	0	2.5	V	
Differential reference voltage, $V_{ref+} - V_{ref-}$ (see Note 2)	1	$V_{CC}$	$V_{CC}+0.2$	1	$V_{CC}$	$V_{CC}+0.2$	V	
Analog input voltage (see Note 2)	0		$V_{CC}$	0		$V_{CC}$	V	
High-level control input voltage, $V_{IH}$	2			2			V	
Low-level control input voltage, $V_{IL}$			0.8			0.8	V	
Setup time, address bits at data input before I/O CLOCK $\uparrow$ , $t_{su}(A)$	200			400			ns	
Hold time, address bits after I/O CLOCK $\uparrow$ , $t_h(A)$	0			0			ns	
Setup time, $\overline{CS}$ low before clocking in first address bit, $t_{su}(CS)$ (see Note 3)	3			3			System clock cycles	
$\overline{CS}$ high during conversion, $t_{WH}(CS)$	36			36			System clock cycles	
I/O CLOCK frequency, $f_{clock(I/O)}$	0		2.048	0		1.1	MHz	
Pulse duration, SYSTEM CLOCK frequency, $f_{clock(SYS)}$	$f_{clock(I/O)}$		4	$f_{clock(I/O)}$		2.1	MHz	
Pulse duration, SYSTEM CLOCK high, $t_{WH}(SYS)$	110			210			MHz	
Pulse duration, SYSTEM CLOCK low, $t_{WL}(SYS)$	100			190			MHz	
Pulse duration, I/O clock high, $t_{WH}(I/O)$	200			404			ns	
Pulse duration, I/O clock low, $t_{WL}(I/O)$	200			404			ns	
Clock transition time (see Note 4)	System	$f_{clock(SYS)} \leq 1048$ kHz	30		30		ns	
		$f_{clock(SYS)} > 1048$ kHz	20		20			
	I/O	$f_{clock(I/O)} \leq 525$ kHz	100		100			
		$f_{clock(I/O)} > 525$ kHz	40		40			
Operating free-air temperature, $T_A$	TLC540I, TLC541I		-40	85		-40	85	°C

- NOTES: 2. Analog input voltages greater than that applied to REF + convert as all "1"s (11111111), while input voltages less than that applied to REF- convert as all "0"s (00000000). For proper operation, REF+ voltage must be at least 1 V higher than REF- voltage. Also, the total unadjusted error may increase as this differential reference voltage falls below 4.75 V.
3. To minimize errors caused by noise at  $\overline{CS}$ , the internal circuitry waits for three SYSTEM CLOCK cycles (or less) after a chip select falling edge is detected before responding to control input signals. Therefore, no attempt should be made to clock in an address until the minimum chip select setup time has elapsed.
4. This is the time required for the clock input signal to fall from  $V_{IH}$  min to  $V_{IL}$  max or to rise from  $V_{IL}$  max to  $V_{IH}$  min. In the vicinity of normal room temperature, the devices function with input clock transition time as slow as 2  $\mu$ s for remote data acquisition applications where the sensor and the A/D converter are placed several feet away from the controlling microprocessor.



**TLC540I, TLC541I**  
**8-BIT ANALOG-TO-DIGITAL CONVERTERS**  
**WITH SERIAL CONTROL AND 11 INPUTS**

SLAS065A – OCTOBER 1983 – REVISED MARCH 1995

**electrical characteristics over recommended operating temperature range,  $V_{CC} = V_{ref+} = 4.75\text{ V}$  to  $5.5\text{ V}$ ,  $f_{clock(I/O)} = 2.048\text{ MHz}$  for TLC540 or  $f_{clock(I/O)} = 1.1\text{ MHz}$  for TLC541 (unless otherwise noted)**

PARAMETER		TEST CONDITIONS	MIN	TYP†	MAX	UNIT
$V_{OH}$	High-level output voltage, DATA OUT	$V_{CC} = 4.75\text{ V}$ , $I_{OH} = 360\text{ }\mu\text{A}$	2.4			V
$V_{OL}$	Low-level output voltage	$V_{CC} = 4.75\text{ V}$ , $I_{OL} = 1.6\text{ mA}$			0.4	V
$I_{OZ}$	Off-state (high-impedance state) output current	$V_O = V_{CC}$ , $\overline{CS}$ at $V_{CC}$			10	$\mu\text{A}$
		$V_O = 0$ , $\overline{CS}$ at $V_{CC}$			-10	
$I_{IH}$	High-level input current	$V_I = V_{CC}$		0.005	2.5	$\mu\text{A}$
$I_{IL}$	Low-level input current	$V_I = 0$		-0.005	-2.5	$\mu\text{A}$
$I_{CC}$	Operating supply current	$\overline{CS}$ at 0 V		1.2	2.5	mA
Selected channel leakage current		Selected channel at $V_{CC}$ , Unselected channel at 0 V		0.4	1	$\mu\text{A}$
		Selected channel at 0 V, Unselected channel at $V_{CC}$		-0.4	-1	
$I_{CC} + I_{ref}$	Supply and reference current	$V_{ref+} = V_{CC}$ , $\overline{CS}$ at 0 V		1.3	3	mA
$C_i$	Input capacitance	Analog inputs		7	55	$\text{pF}$
		Control inputs		5	15	

† All typical values are at  $T_A = 25^\circ\text{C}$ .

# TLC540I, TLC541I

## 8-BIT ANALOG-TO-DIGITAL CONVERTERS

### WITH SERIAL CONTROL AND 11 INPUTS

SLAS065A – OCTOBER 1983 – REVISED MARCH 1995

operating characteristics over recommended operating free-air temperature range,  
 $V_{CC} = V_{ref+} - 4.75\text{ V to } 5.5\text{ V}$ ,  $f_{clock(I/O)} = 2.048\text{ MHz for TLC540 or } 1.1\text{ MHz for TLC541}$ ,  
 $f_{clock(SYS)} = 4\text{ MHz for TLC540 or } 2.1\text{ MHz for TLC541}$

PARAMETER	TEST CONDITIONS	TLC540		TLC541		UNIT
		MIN	MAX	MIN	MAX	
$E_L$ Linearity error	See Note 5	±0.5		±0.5		LSB
$E_{ZS}$ Zero-scale error	See Notes 2 and 6	±0.5		±0.5		LSB
$E_{FS}$ Full-scale error	See Notes 2 and 6	±0.5		±0.5		LSB
Total unadjusted error	See Note 7	±0.5		±0.5		LSB
Self-test output code	Input A11 address = 1011, (see Note 8)	01111101 (125)	10000011 (131)	01111101 (125)	10000011 (131)	
$t_{conv}$ Conversion time	See Operating Sequence	9		17		μs
Total access and conversion time	See Operating Sequence	13.3		25		μs
$t_a$ Channel acquisition time (sample cycle)	See Operating Sequence	4		4		I/O clock cycles
$t_v$ Time output data remains valid after I/O CLOCK↓		10		10		ns
$t_d$ Delay time, I/O CLOCK↓ to data output valid	See Parameter Measurement Information	300		400		ns
$t_{en}$ Output enable time		150		150		ns
$t_{dis}$ Output disable time		150		150		ns
$t_{r(bus)}$ Data bus rise time		300		300		ns
$t_{f(bus)}$ Data bus fall time		300		300		ns

- NOTES:
- Analog input voltages greater than that applied to REF+ convert to all "1"s (11111111) while input voltages less than that applied to REF- convert to all "0"s (00000000). For proper operation, REF+ voltage must be at least 1 V higher than REF- voltage. Also, the total unadjusted error may increase as this differential reference voltage falls below 4.75 V.
  - Linearity error is the maximum deviation from the best straight line through the A/D transfer characteristics.
  - Zero-scale error is the difference between 00000000 and the converted output for zero input voltage; full-scale error is the difference between 11111111 and the converted output for full-scale input voltage.
  - Total unadjusted error is the sum of linearity, zero-scale, and full-scale errors.
  - Both the input address and the output codes are expressed in positive logic.



PARAMETER MEASUREMENT INFORMATION

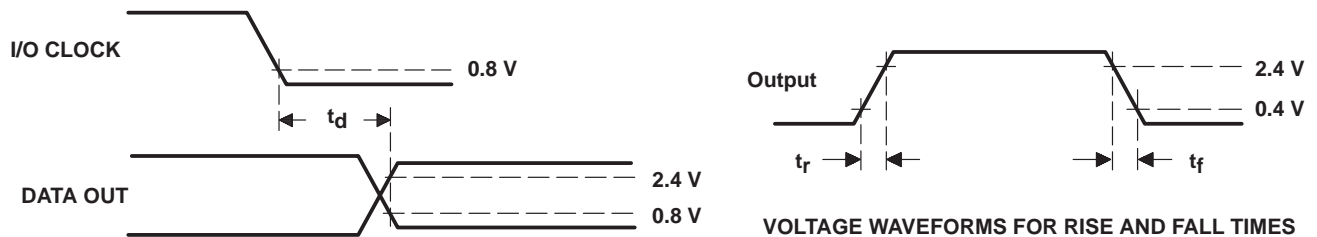
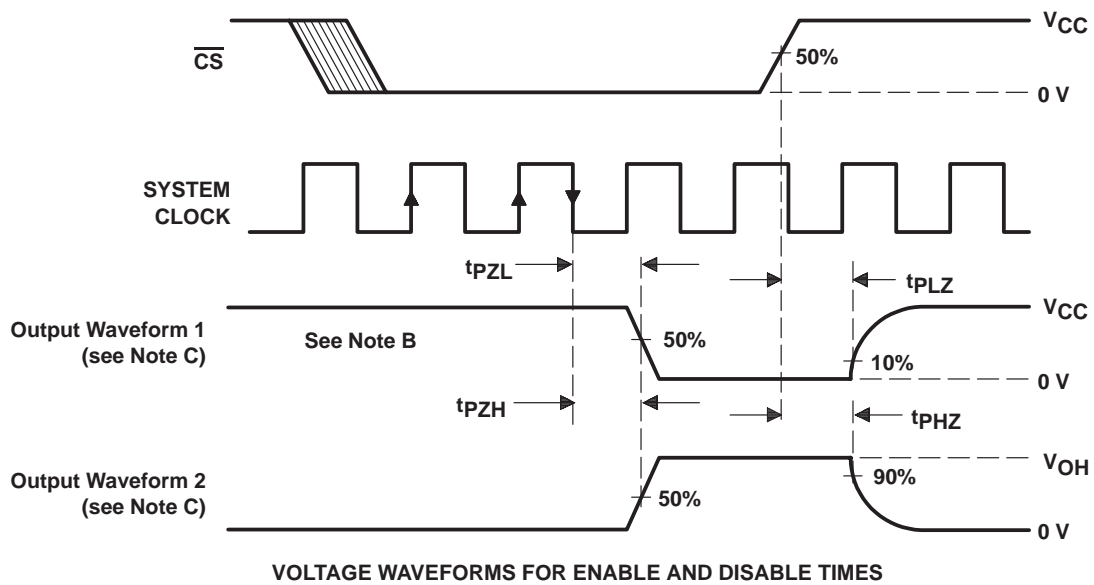
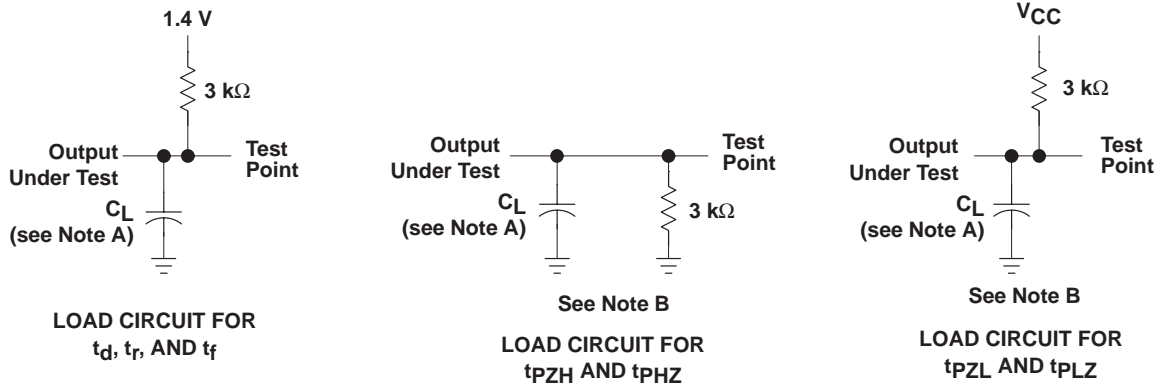

VOLTAGE WAVEFORMS FOR DELAY TIME

- NOTES: A.  $C_L = 50 \text{ pF}$  for TLC540 and  $100 \text{ pF}$  for TLC541.  
 B.  $t_{en} = t_{pZH}$  or  $t_{pZL}$ ,  $t_{dis} = t_{pHZ}$  or  $t_{pLZ}$ .  
 C. Waveform 1 is for an output with internal conditions such that the output is low except when disabled by the output control. Waveform 2 is for an output with internal conditions such that the output is high except when disabled by the output control.

APPLICATION INFORMATION

simplified analog input analysis

Using the equivalent circuit in Figure 1, the time required to charge the analog input capacitance from 0 to  $V_S$  within 1/2 LSB can be derived as follows:

The capacitance charging voltage is given by

$$V_C = V_S \left( 1 - e^{-t_c / R_t C_i} \right) \tag{1}$$

where

$$R_t = R_S + r_i$$

The final voltage to 1/2 LSB is given by

$$V_C (1/2 \text{ LSB}) = V_S - (V_S/512) \tag{2}$$

Equating equation 1 to equation 2 and solving for time  $t_c$  gives

$$V_S - (V_S/512) = V_S \left( 1 - e^{-t_c / R_t C_i} \right) \tag{3}$$

and

$$t_c (1/2 \text{ LSB}) = R_t \times C_i \times \ln(512) \tag{4}$$

Therefore, with the values given the time for the analog input signal to settle is

$$t_c (1/2 \text{ LSB}) = (R_S + 1 \text{ k}\Omega) \times 60 \text{ pF} \times \ln(512) \tag{5}$$

This time must be less than the converter sample time shown in the timing diagrams.

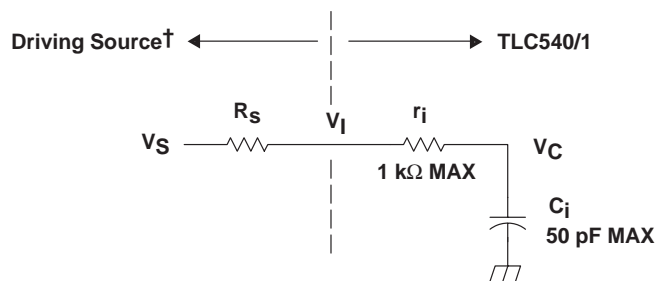

$V_I$  = Input Voltage at INPUT A0–A10  
 $V_S$  = External Driving Source Voltage  
 $R_S$  = Source Resistance  
 $r_i$  = Input Resistance  
 $C_i$  = Equivalent Input Capacitance

† Driving source requirements:

- Noise and distortion for the source must be equivalent to the resolution of the converter.
- $R_S$  must be real at the input frequency.

Figure 1. Equivalent Input Circuit Including the Driving Source



---

## PRINCIPLES OF OPERATION

The TLC540 and TLC541 are each complete data acquisition systems on a single chip. They include such functions as analog multiplexer, sample and hold, 8-bit A/D converter, data and control registers, and control logic. For flexibility and access speed, there are four control inputs [two clocks, chip select ( $\overline{CS}$ ), and address]. These control inputs and a TTL-compatible 3-state output are intended for serial communications with a microprocessor or microcomputer. With judicious interface timing, with TLC540 a conversion can be completed in 9  $\mu$ s, while complete input-conversion-output cycles can be repeated every 13  $\mu$ s. With TLC541 a conversion can be completed in 17  $\mu$ s, while complete input-conversion-output cycles are repeated every 25  $\mu$ s. Furthermore, this fast conversion can be executed on any of 11 inputs or its built-in self-test and in any order desired by the controlling processor.

The system and I/O clocks are normally used independently and do not require any special speed or phase relationships between them. This independence simplifies the hardware and software control tasks for the device. Once a clock signal within the specification range is applied to SYSTEM CLOCK, the control hardware and software need only be concerned with addressing the desired analog channel, reading the previous conversion result, and starting the conversion by using I/O CLOCK. SYSTEM CLOCK will drive the conversion crunching circuitry so that the control hardware and software need not be concerned with this task.

When  $\overline{CS}$  is high, DATA OUT is in a 3-state condition and ADDRESS INPUT and I/O CLOCK are disabled. This feature allows each of these terminals, with the exception of  $\overline{CS}$ , to share a control logic point with their counterpart terminals on additional A/D devices when additional TLC540/541 devices are used. In this way, the above feature serves to minimize the required control logic terminals when using multiple A/D devices.

The control sequence has been designed to minimize the time and effort required to initiate conversion and obtain the conversion result. A normal control sequence is:

1.  $\overline{CS}$  is brought low. To minimize errors caused by noise at  $\overline{CS}$ , the internal circuitry waits for two rising edges and then a falling edge of SYSTEM CLOCK after a low  $\overline{CS}$  transition, before the low transition is recognized. This technique is used to protect the device against noise when the device is used in a noisy environment. The MSB of the previous conversion result automatically appears on DATA OUT.
2. A new positive-logic multiplexer address is shifted in on the first four rising edges of I/O CLOCK. The MSB of the address is shifted in first. The negative edges of these four I/O clock pulses shift out the second, third, fourth, and fifth most significant bits of the previous conversion result. The on-chip sample and hold begins sampling the newly addressed analog input after the fourth falling edge. The sampling operation basically involves the charging of internal capacitors to the level of the analog input voltage.
3. Three clock cycles are then applied to I/O CLOCK and the sixth, seventh, and eighth conversion bits are shifted out on the negative edges of these clock cycles.
4. The final eighth clock cycle is applied to I/O CLOCK. The falling edge of this clock cycle completes the analog sampling process and initiates the hold function. Conversion is then performed during the next 36 system clock cycles. After this final I/O clock cycle,  $\overline{CS}$  must go high or the I/O CLOCK must remain low for at least 36 system clock cycles to allow for the conversion function.

$\overline{CS}$  can be kept low during periods of multiple conversion. When keeping  $\overline{CS}$  low during periods of multiple conversion, special care must be exercised to prevent noise glitches on I/O CLOCK. If glitches occur on I/O CLOCK, the I/O sequence between the microprocessor/controller and the device loses synchronization. Also, if  $\overline{CS}$  is taken high, it must remain high until the end of the conversion. Otherwise, a valid falling edge of  $\overline{CS}$  causes a reset condition, which aborts the conversion in progress.

A new conversion can be started and the ongoing conversion simultaneously aborted by performing steps 1 through 4 before the 36 system clock cycles occur. Such action yields the conversion result of the previous conversion and not the ongoing conversion.

# TLC540I, TLC541I

## 8-BIT ANALOG-TO-DIGITAL CONVERTERS

### WITH SERIAL CONTROL AND 11 INPUTS

SLAS065A – OCTOBER 1983 – REVISED MARCH 1995

---

#### PRINCIPLES OF OPERATION

It is possible to connect SYSTEM CLOCK and I/O clock together in special situations in which controlling circuitry points must be minimized. In this case, the following special points must be considered in addition to the requirements of the normal control sequence previously described.

1. The first two clocks are required for this device to recognize  $\overline{CS}$  is at a valid low level when the common clock signal is used as an I/O CLOCK. When  $\overline{CS}$  is recognized by the device to be at a high level, the common clock signal is used for the conversion clock also.
2. A low  $\overline{CS}$  must be recognized before the I/O CLOCK can shift in an analog channel address. The device recognizes a  $\overline{CS}$  transition when the SYSTEM CLOCK terminal receives two positive edges and then a negative edge. For this reason, after a  $\overline{CS}$  negative edge, the first two clock cycles do not shift in the address. Also, upon shifting in the address,  $\overline{CS}$  must be raised after the eighth valid (10 total) I/O CLOCK. Otherwise, additional common clock cycles are recognized as I/O CLOCKS and will shift in an erroneous address.

For certain applications, such as strobing applications, it is necessary to start conversion at a specific point in time. This device accommodates these applications. Although the on-chip sample and hold begins sampling upon the negative edge of the fourth valid I/O clock cycle, the hold function is not initiated until the negative edge of the eighth valid I/O clock cycle. Thus, the control circuitry can leave the I/O clock signal in its high state during the eighth valid I/O clock cycle until the moment at which the analog signal must be converted. The TLC540/TLC541 continues sampling the analog input until the eighth falling edge of the I/O clock. The control circuitry or software then immediately lowers the I/O clock signal and holds the analog signal at the desired point in time and start conversion.

Detailed information on interfacing to most popular microprocessors is readily available from the factory.



POST OFFICE BOX 655303 • DALLAS, TEXAS 75265

## **IMPORTANT NOTICE**

Texas Instruments and its subsidiaries (TI) reserve the right to make changes to their products or to discontinue any product or service without notice, and advise customers to obtain the latest version of relevant information to verify, before placing orders, that information being relied on is current and complete. All products are sold subject to the terms and conditions of sale supplied at the time of order acknowledgement, including those pertaining to warranty, patent infringement, and limitation of liability.

TI warrants performance of its semiconductor products to the specifications applicable at the time of sale in accordance with TI's standard warranty. Testing and other quality control techniques are utilized to the extent TI deems necessary to support this warranty. Specific testing of all parameters of each device is not necessarily performed, except those mandated by government requirements.

**CERTAIN APPLICATIONS USING SEMICONDUCTOR PRODUCTS MAY INVOLVE POTENTIAL RISKS OF DEATH, PERSONAL INJURY, OR SEVERE PROPERTY OR ENVIRONMENTAL DAMAGE ("CRITICAL APPLICATIONS"). TI SEMICONDUCTOR PRODUCTS ARE NOT DESIGNED, AUTHORIZED, OR WARRANTED TO BE SUITABLE FOR USE IN LIFE-SUPPORT DEVICES OR SYSTEMS OR OTHER CRITICAL APPLICATIONS. INCLUSION OF TI PRODUCTS IN SUCH APPLICATIONS IS UNDERSTOOD TO BE FULLY AT THE CUSTOMER'S RISK.**

In order to minimize risks associated with the customer's applications, adequate design and operating safeguards must be provided by the customer to minimize inherent or procedural hazards.

TI assumes no liability for applications assistance or customer product design. TI does not warrant or represent that any license, either express or implied, is granted under any patent right, copyright, mask work right, or other intellectual property right of TI covering or relating to any combination, machine, or process in which such semiconductor products or services might be or are used. TI's publication of information regarding any third party's products or services does not constitute TI's approval, warranty or endorsement thereof.