



# LB1998

## Three-Phase Brushless Motor Driver for CD-ROM Spindle Drive

### Overview

The LB1998 is a three-phase brushless motor driver especially suited for CD-ROM spindle motor drives.

### Functions

- Current linear drive
- Control V type amplifier
- Top side current detection technique reduces loss voltage of current detection resistor. Voltage effect of this resistor reduces internal current drain of IC.
- Built-in current limiter circuit
- Built-in reverse blocking circuit
- Hall FG output
- Built-in 1 Hall FG/3 Hall FG switching circuit
- Built-in short braking circuit
- Built-in Hall bias circuit
- Built-in thermal shutdown circuit
- Built-in S/S function
- Built-in 3 mode gain switching function ensures compatibility with 8/12 cm CAV and CLV discs

### Package Dimensions

unit: mm

#### 3234-HSOP28HC

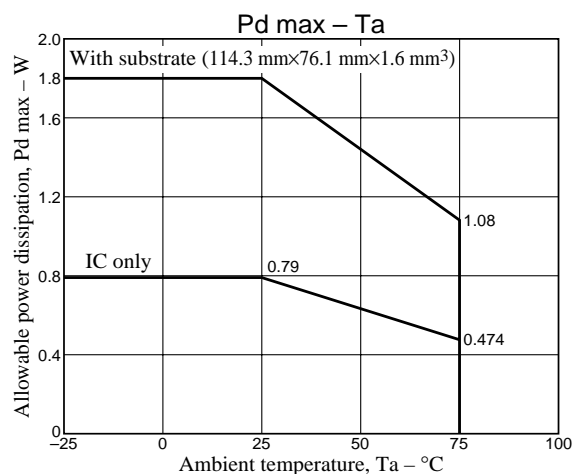
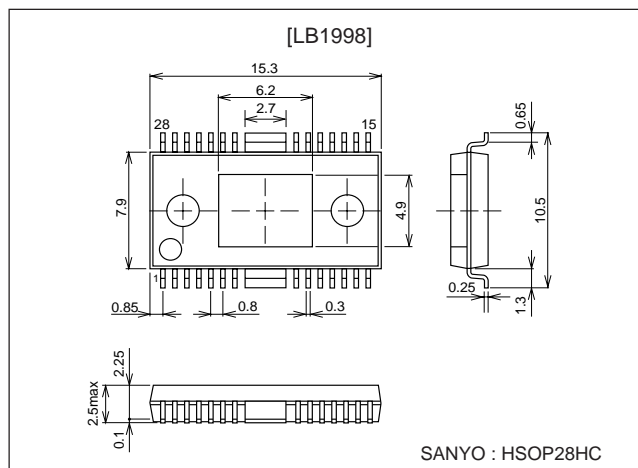

■ Any and all SANYO products described or contained herein do not have specifications that can handle applications that require extremely high levels of reliability, such as life-support systems, aircraft's control systems, or other applications whose failure can be reasonably expected to result in serious physical and/or material damage. Consult with your SANYO representative nearest you before using any SANYO products described or contained herein in such applications.

■ SANYO assumes no responsibility for equipment failures that result from using products at values that exceed, even momentarily, rated values (such as maximum ratings, operating condition ranges, or other parameters) listed in products specifications of any and all SANYO products described or contained herein.

## Specifications

### Maximum Ratings at Ta = 25°C

Parameter	Symbol	Conditions	Ratings	Unit
Power supply voltage	V <sub>CC1</sub> max		7.0	V
	V <sub>CC2</sub> max		14.4	V
	V <sub>CC3</sub> max		14.4	V
Applied output voltage	V <sub>O</sub> max		14.4	V
Applied input voltage	V <sub>IN</sub> max		V <sub>CC1</sub>	V
Output current	I <sub>O</sub> max		1.3	A
Allowable power dissipation	Pd max	IC only	0.79	W
		with substrate (114.3 × 76.1 × 1.6 mm <sup>3</sup> , glass epoxy)	1.80	W
Operating temperature	T <sub>opr</sub>		-20 to +75	°C
Storage temperature	T <sub>stg</sub>		-55 to +150	°C

### Operating Conditions at Ta = 25°C

Parameter	Symbol	Conditions	Ratings	Unit
Power supply voltage	V <sub>CC1</sub>		4 to 6	V
	V <sub>CC2</sub>	≥V <sub>CC1</sub>	4 to 13.6	V

### Sample Application at Ta = 25°C

Parameter	Symbol	Conditions	Ratings	Unit
12V type	V <sub>CC1</sub>	Regulated voltage	4 to 6	V
	V <sub>CC2</sub>	Unregulated voltage	4 to 13.6	V

# LB1998

## Electrical Characteristics at Ta = 25°C, V<sub>CC1</sub> = 5V, V<sub>CC2</sub> = 12V

Parameter	Symbol	Conditions	Ratings			Unit
			min	typ	max	
[Power supply current]						
Power supply current	I <sub>CC1</sub>	V <sub>CIN</sub> = V <sub>CREF</sub>		8		mA
	I <sub>CC2</sub>	V <sub>CIN</sub> = V <sub>CREF</sub>		250	300	mA
Output idle current	I <sub>CC1OQ</sub>	V <sub>S/S</sub> = 0V			200	μA
	I <sub>CC2OQ</sub>	V <sub>S/S</sub> = 0V			60	μA
[Output]						
Saturation voltage, upper side 1	V <sub>OU1</sub>	I <sub>O</sub> = -0.5A, V <sub>CC1</sub> = 5V, V <sub>CC2</sub> = 12V		1.0		V
Saturation voltage, lower side 1	V <sub>OD1</sub>	I <sub>O</sub> = 0.5A, V <sub>CC1</sub> = 5V, V <sub>CC2</sub> = 12V		0.3		V
Current limiter setting voltage	V <sub>CL</sub>	R <sub>RF</sub> = 0.25Ω		0.25		V
[Hall amplifier]						
Common mode input voltage range	V <sub>HCOM</sub>		1.2		V <sub>CC1</sub> -1.0	V
Input bias current	I <sub>HIB</sub>			1		μA
Minimum Hall input level	V <sub>HIN</sub>		60			mV <sub>P-P</sub>
[S/S pin]						
High level voltage	V <sub>S/SH</sub>		2.0		V <sub>CC1</sub>	V
Low level voltage	V <sub>S/SL</sub>				0.7	V
Input current	I <sub>S/SI</sub>	V <sub>S/S</sub> = 5V			200	μA
Leak current	I <sub>S/SL</sub>	V <sub>S/S</sub> = 0V	-30			μA
[Control]						
V <sub>CIN</sub> pin input current	I <sub>VC</sub>	V <sub>CIN</sub> = V <sub>CREF</sub> = 1.65V			1	μA
V <sub>CREF</sub> pin input current	I <sub>VCREF</sub>	V <sub>CIN</sub> = V <sub>CREF</sub> = 1.65V			1	μA
Voltage gain	G <sub>VCO</sub>	ΔV <sub>RF</sub> /ΔV <sub>C</sub> , Note 1		0.25		times
Startup voltage	V <sub>CTH</sub>	V <sub>CREF</sub> = 1.65V, Note 1	1.55		1.85	V
Startup voltage width	ΔV <sub>CTH</sub>	V <sub>CREF</sub> = 1.65V, Note 1	100		200	mV
[Gain switching amplifier]						
Input offset voltage	V <sub>GCOFFSET</sub>	Design target value	-8		+8	mV
OPEN LOOP voltage gain	G <sub>VGC</sub>	f = 10 kHz, Design target value		43		dB
Same-phase input voltage range	V <sub>GCOM</sub>		0		3.5	V
[Hall power supply]						
Hall power supply voltage	V <sub>H</sub>	I <sub>H</sub> = 5 mA		0.8		V
Allowable current	I <sub>H</sub>		20			mA
[Thermal shutdown]						
Operating temperature	T <sub>TSD</sub>	Design target value	150	180	210	°C
Hysteresis	ΔT <sub>TSD</sub>	Design target value		15		°C
[Short braking]						
Brake pin at High level	V <sub>BRH</sub>		4		5	V
Brake pin at Low level	V <sub>BRL</sub>		0		1	V
[1 Hall FG/3 Hall FG switching]						
FG <sub>SEL</sub> pin at High level	V <sub>FSH</sub>		4		5	
FG <sub>SEL</sub> pin at Low level	V <sub>FSL</sub>		0		1	
[Gain switching analog switch]						
Analog switch at High level	R <sub>INH</sub>		V <sub>CC</sub> -0.5		V <sub>CC1</sub>	
Analog switch at Low level	R <sub>INL</sub>		0		0.2	

Note:

- During S/S OFF (standby), the Hall comparator is at High.
- Gain switching amplifier operated at a factor of 1.
- Design target values are not measured.

**Truth Table**

	Source → Sink	Hall input			Control $V_{CIN}$
		U	V	W	
1	Phase W → Phase V	H	H	L	H
	Phase V → Phase W				L
2	Phase W → Phase U	H	L	L	H
	Phase U → Phase W				L
3	Phase V → Phase W	L	L	H	H
	Phase W → Phase V				L
4	Phase U → Phase V	L	H	L	H
	Phase V → Phase U				L
5	Phase V → Phase U	H	L	H	H
	Phase U → Phase V				L
6	Phase U → Phase W	L	H	H	H
	Phase W → Phase U				L

Input:

H: Input 1 is higher in potential than input 2 by at least 0.2V.

L: Input 1 is lower in potential than input 2 by at least 0.2V.

**Brake Mode Switching Truth Table**

BRAKE pin	$V_{CIN} > V_{CREF}$	$V_{CIN} < V_{CREF}$
L, OPEN	Foward	Reverse brake
H	Foward	Short brake

**Pin Assignment**

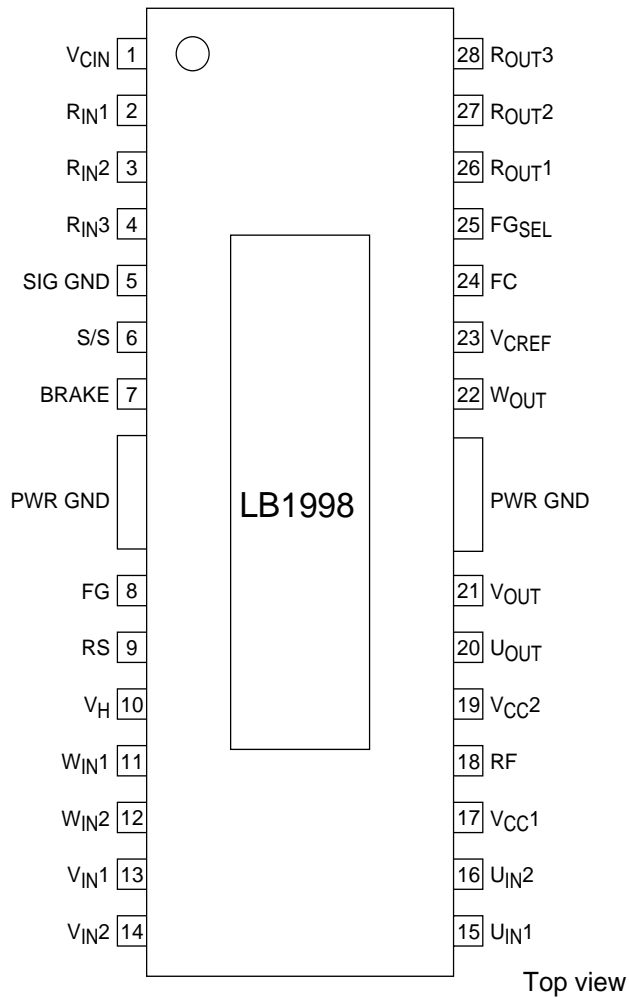

Block Diagram

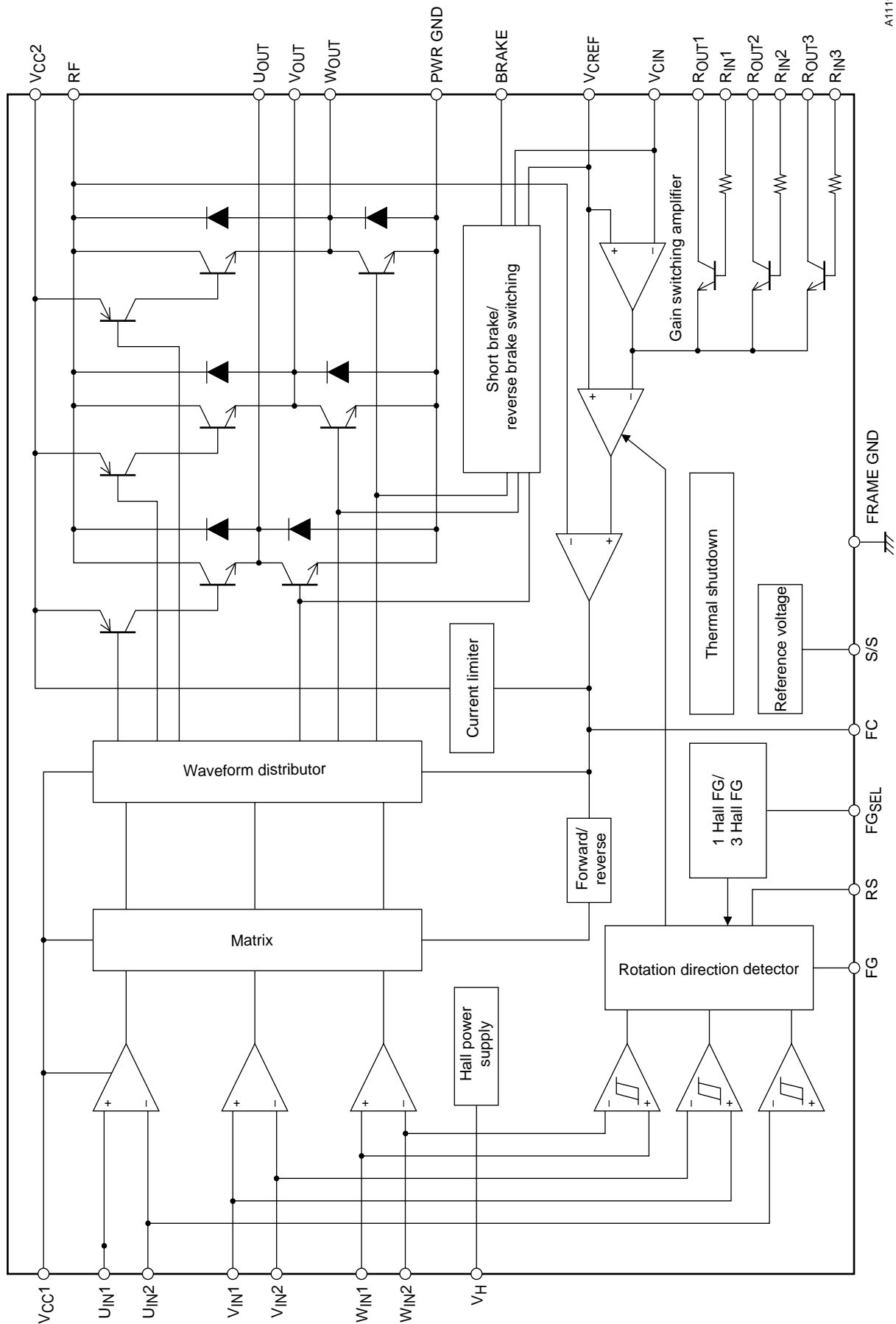

A11193

# LB1998

## Sample Application Circuit

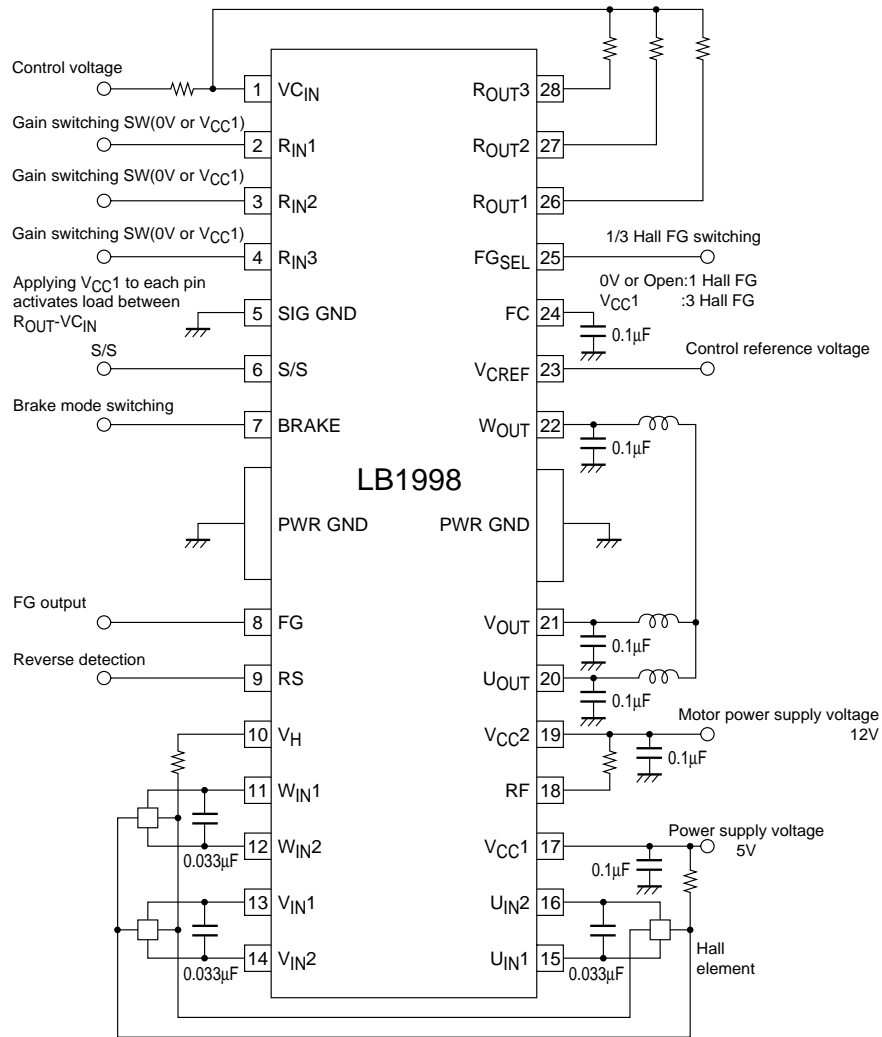

A11195

Pin Descriptions

Pin number	Pin name	Pin voltage	Equivalent circuit	Pin function
19	V <sub>CC2</sub>	4V to 13.6V		Source side predrive voltage and constant current control amplifier voltage supply pin
17	V <sub>CC1</sub>	4V to 6V		Power supply pin for all circuits except output transistors, source predriver, and low current control amplifier
9	RS			Reverse detector pin Forward rotation: High Reverse rotation: Low
8	FG			1 Hall or 3 Hall element waveform Schmitt comparator combined output
15 16	U <sub>IN1</sub> U <sub>IN2</sub>	1.2V to V <sub>CC1</sub> -1V		U phase Hall element input and reverse detector U phase Schmitt comparator input pin Logic High indicates U <sub>IN1</sub> > U <sub>IN2</sub> .
13 14	V <sub>IN1</sub> V <sub>IN2</sub>			V phase Hall element input and reverse detector V phase Schmitt comparator input pin Logic High indicates V <sub>IN1</sub> > V <sub>IN2</sub> .
11 12	W <sub>IN1</sub> W <sub>IN2</sub>			W phase Hall element input and reverse detector W phase Schmitt comparator input pin Logic High indicates W <sub>IN1</sub> > W <sub>IN2</sub> .
10	V <sub>H</sub>			Hall element lower side bias voltage supply pin
6	S/S	0V to W <sub>CC1</sub>		When this pin is at 0.7V or lower, or when it is open, all circuits are inactive. When driving motor, set this pin to 2V or higher.
5	SIG GND			GND pin for all circuits except output
24	FC			Control loop frequency compensator pin. Connecting a capacitor between this pin and GND prevents closed loop oscillation in current limiting circuitry.

Continued on next page

# LB1998

Continued from preceding page

Pin number	Pin name	Pin voltage	Equivalent circuit	Pin function
23	V <sub>CREF</sub>	0V to 3.5V		Control reference voltage supply pin. Determines control start voltage.
1	V <sub>CIN</sub>	0V to 3.5V		Speed control voltage supply pin V type control technique V <sub>C</sub> > V <sub>CREF</sub> : Forward V <sub>C</sub> < V <sub>CREF</sub> : Slowdown (Reverse-blocking circuit prevents reverse rotation.)
22	W <sub>OUT</sub>			W phase output
	PWR GND			Output transistor GND
21	V <sub>OUT</sub>			V phase output
20	U <sub>OUT</sub>			U phase output
18	RF			Upper side output PNP transistor collector pin (common for all 3 phases). For current detection, connect resistor between V <sub>CC3</sub> pin and RF pin. Constant current control and current limiter works by detecting this voltage.
25	FG <sub>SEL</sub>			1 Hall FG/3 Hall FG output, switching pin: High → 3 Hall FG Low/Open → 1 Hall FG
7	BRAKE			Brake mode switching pin BRAKE: High → Short brake Low/Open → Reverse brake Brake mode changes when V <sub>CIN</sub> > V <sub>CREF</sub> .

Continued on next page



Continued from preceding page

Pin number	Pin name	Pin voltage	Equivalent circuit	Pin function
2	R <sub>IN1</sub>	0 to V <sub>CC1</sub> Low: 0V High: V <sub>CC1</sub>		Gain switching selector pin When set to High (V <sub>CC1</sub> ), resistor connected between R <sub>OUT1</sub> and V <sub>CIN</sub> is selected as negative feedback resistor.
3	R <sub>IN2</sub>			Gain switching selector pin When set to High (V <sub>CC1</sub> ), resistor connected between R <sub>OUT2</sub> and V <sub>CIN</sub> is selected as negative feedback resistor.
4	R <sub>IN3</sub>			Gain switching selector pin When set to High (V <sub>CC1</sub> ), resistor connected between R <sub>OUT3</sub> and V <sub>CIN</sub> is selected as negative feedback resistor.
26	R <sub>OUT1</sub>			Negative feedback resistor connector pins Connect negative feedback resistors between these pins and V <sub>CIN</sub> .
27	R <sub>OUT2</sub>			
28	R <sub>OUT3</sub>			

- Specifications of any and all SANYO products described or contained herein stipulate the performance, characteristics, and functions of the described products in the independent state, and are not guarantees of the performance, characteristics, and functions of the described products as mounted in the customer's products or equipment. To verify symptoms and states that cannot be evaluated in an independent device, the customer should always evaluate and test devices mounted in the customer's products or equipment.
- SANYO Electric Co., Ltd. strives to supply high-quality high-reliability products. However, any and all semiconductor products fail with some probability. It is possible that these probabilistic failures could give rise to accidents or events that could endanger human lives, that could give rise to smoke or fire, or that could cause damage to other property. When designing equipment, adopt safety measures so that these kinds of accidents or events cannot occur. Such measures include but are not limited to protective circuits and error prevention circuits for safe design, redundant design, and structural design.
- In the event that any or all SANYO products(including technical data, services) described or contained herein are controlled under any of applicable local export control laws and regulations, such products must not be exported without obtaining the export license from the authorities concerned in accordance with the above law.
- No part of this publication may be reproduced or transmitted in any form or by any means, electronic or mechanical, including photocopying and recording, or any information storage or retrieval system, or otherwise, without the prior written permission of SANYO Electric Co., Ltd.
- Any and all information described or contained herein are subject to change without notice due to product/technology improvement, etc. When designing equipment, refer to the "Delivery Specification" for the SANYO product that you intend to use.
- Information (including circuit diagrams and circuit parameters) herein is for example only ; it is not guaranteed for volume production. SANYO believes information herein is accurate and reliable, but no guarantees are made or implied regarding its use or any infringements of intellectual property rights or other rights of third parties.

This catalog provides information as of June, 1999. Specifications and information herein are subject to change without notice.

This datasheet has been download from:

[www.datasheetcatalog.com](http://www.datasheetcatalog.com)

Datasheets for electronics components.